

As Per The Syllabus of 1st Year B Tech, APJ Abdul Kalam Technological University, Kerala
(2019 Scheme)

BASICS OF CIVIL AND MECHANICAL ENGINEERING

SANTHA MINU
DR.P BALACHANDRAN



OWL BOOKS

EST
120

BASICS OF CIVIL AND MECHANICAL ENGINEERING

Authors: Santha Minu , Dr. P. Balachandran

COPYRIGHT RESERVED

The articles published in this book are subject to copyright, no material can be reproduced without permission of the publisher. The publisher shall be obliged if mistakes are brought to their notice, including valuable suggestions.

All rights reserved. No part of this publication may be reproduced, distributed, or transmitted in any form or by any means, including photocopying, recording, or other electronic or mechanical methods, without the prior written permission of the publisher except in the case of brief quotations embodied in critical reviews and certain other noncommercial uses permitted by copyright law.

The Publishers of this book states that the Author(s) of this book has taken the full responsibility for the content of this book, any dispute and copyright violation arising based on the content of this book will be addressed by the author(s), furthermore, the authors indemnify the publisher from damages arising from such disputes and copyright violation as stated above.

Acknowledgement: Some view graphs and pictures portrayed in this book has been adopted from different sources for which the author wish to express her sincere gratitude.

Cover design : BAJ Publishers Delhi

Typeset : Owl Books

Printed at : Jasmin Printers.

Graphics-Deign : Owl books

ISBN no. 9789385666964



Published and Distributed by

OWL BOOKS

G.N.R.A.-60, Near GPO,

Gandhari Amman Kovil road,

Thiruvananthapuram, Kerala. Pin 695001

e-mail : mailowlbooks@gmail.com Tel no. 98475 98375

BASICS OF CIVIL AND MECHANICAL ENGINEERING

SANTHA MINU
DR. P BALACHANDRAN

About the book

This book provides students with a sound understanding of the theory, problems and worked out examples of 'basics of civil and mechanical engineering'. It describes in an easy to follow style and with applications. This book is the result of the authors's experience with students of various disciplines in the fields spanning over a period of 20 years. we hope that this edition should prove a boon to the students and help them to acquire a sound knowledge of this subject without which a really satisfactory progress cannot be achieved in any branch of engineering.

The authors will always welcome suggestions, if any...



OWL BOOKS

GNRA -60, Near G.P.O. Ghandhari Amman Kovil Road
Trivandrum. Kerala - 695 001
Mail: mailowlbooks@gmail.com
Web: www.owlbooks.in
Ph +91 98475 98375

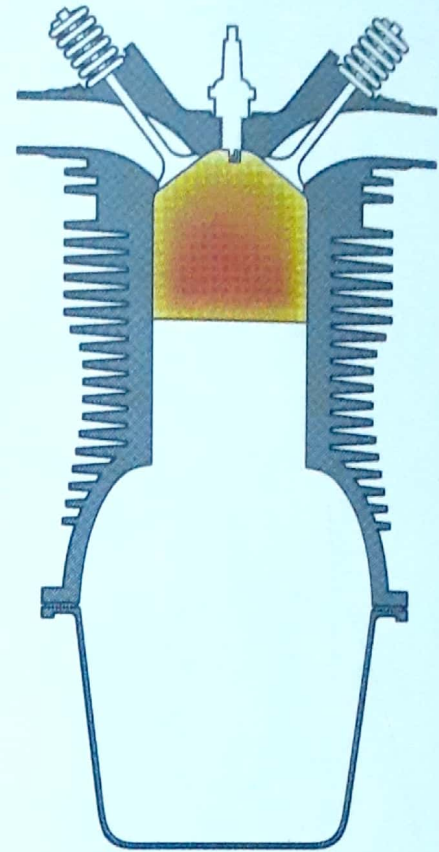

Civil Engineering

1.1 INTRODUCTION

Civil engineering is a broad field of engineering dealing with the planning, design, construction, maintenance and management of physical infrastructure facility such as buildings, towers, bridges, roads, railway, airport, dams, canals, water supply system and sewerage system, etc. Just like other Engineering field there are some developments happened in Civil Engineering and now we are able to construct towers like Burj Khalib, Burj Al Arab etc. Flood resistant and earthquake resistant buildings are made by us.

1.1.1 Relevance of Civil Engineering in the Infrastructural Development of the country

Infrastructure is the framework of supporting system consisting of roads, airports, bridges, buildings, parks and other amenities for the comfort of people. In economic point of view, infrastructure are the structural elements that help the production of goods and services without being a part of the production process, e.g. roads allow the transport of raw materials and finished products.

Infrastructure deals with the following:

- i. Transportation – Road Network, Railway, Ports & Harbors, Air travel and Airports
- ii. Television Network
- iii. Telephone Network – Landline and Mobile phone connections
- iv. Energy Sector – Electrification, reduction in energy loss, use of renewable energy such as Solar, Wind, Biogas plants.
- v. Educational facility - Proximity of good primary and secondary schools, College and professional education.
- vi. Good health care facility- Primary health centres, specialised hospitals and doctors.
- vii. Agricultural Activity
- viii. Construction Activity

Out of these activities, agriculture got the first preference and second preference is for construction activity.

1.1.2 Role of Civil engineering in the infrastructural development

A civil engineer has to conceive, plan, design, estimate, get approval, create and maintain all civil engineering activities. Civil engineer has very important role in the development of the following infrastructure:

- i. Measure and map the earth's surface.
- ii. Plan new townships and extension of existing towns.
- iii. Build the suitable structures for the rural and urban areas for various utilities.
- iv. Construction and commissioning of well planned and designed dams, water treatment plants, water supply schemes and sewerage disposal schemes.
- v. Construction of Well planned and designed roads, railways, airports and harbours.
- vi. Devise systems for control and efficient flow of traffic.
- vii. Rehabilitation and rebuilding of structures.
- viii. Build canals and distributaries to take water to agricultural fields.
- ix. Creating a pollution free environmental condition.
- x. Planning of towns and extension areas in the cities for accommodating offices, schools, colleges, hospitals, market, recreational facilities and residential areas.
- xii. Build river navigation and flood control projects.
- xiii. Fast growing industrialization has put heavy responsibilities on civil engineers to preserve and protect environment.
- xiv. Rebuilding, Rehabilitation, Retrofitting and Repair

1.1.3 Impact of infrastructural development of a country

- i. Due to improvement in irrigation facility food production will increase.
- ii. It will give protection from drought, famine and flood.
- iii. Improved education and Healthy care of society will produces skilled and health manpower.
- iv. Improved water supply sector will ensure safe domestic and industrial water supply.
- v. Improved sewerage system will ensure safe and scientific waste disposal.
- vi. Internet, telephone and transportation will raise the status and economy of nation.
- vii. Generation of electricity from, nuclear, hydel, thermal, solar or wind energy will improve the living status of people.
- viii. Overall improvement in wealth, prosperity, standard of living of public and this leads to overall growth of a nation.
- ix. Educational facility also forms part of infrastructure. Proximity of good primary and secondary schools to residential areas is desirable. Collegiate and professional education also forms part of infrastructure of a city.
- x. A well planned and built network of roads and road crossings will improve economy of the nation.

1.1.4 Impact of infrastructural facility on socio-economic growth of a Nation

- i. Large scale budget allocation for infrastructure leads to agricultural and industrial developments.
- ii. Provide employment to a large set of people there by enhances per capita income.
- iii. Urban growth only can lead to population drift from rural sectors leading to explosion in population in cities and inadequate development of villages and improper care for agricultural sector.
- iv. Use of infrastructural facility only by upper class leads to imbalance.
- v. Improved economical status of the country will give respectable status in world.

1.2 RESPONSIBILITY OF AN ENGINEER IN ENSURING THE SAFETY OF ENVIRONMENT:

As human beings share a common environment, a common ecosphere, urgent concerns for that environment must increasingly become a united commitment of us. Many experts says that we are missusing our scare resources, fouling our environment. Industrial activities pollutes our land, water and air, which leads to diminishing harvest from land and sea. It also create some new diseases.

Civil engineers shall be committed to the following Principles :

Principle 1 - Do the Right Project. A proposed project's economic, environmental and social effects on each of the communities served and affected must be assessed and understood by all stakeholders before there is a decision to proceed with a project. Consider non-structural as well as structural (built) solutions to the needs being addressed.

Principle 2 - Do the Project Right. The civil engineer shall actively engage stakeholders and secure public understanding and acceptance of a projects economic, environmental and social costs and benefits. To move toward conditions of sustainability, engineers must design and deliver projects that address sustainability holistically from the concept to demolition or reuse rather than adding a variety of "green" features onto a conventional project.

Engineers shall recognize that the lives, safety, health and welfare of the general public are dependent upon engineering judgments, decisions and practices incorporated into structures, machines, products, processes and devices.

Civil Engineers design and supervise the construction of buildings, roads, runways, railway tunnels, bridges, dams, water tanks, water supply and sewerage systems. All construction works of large scale needs guidance of a civil engineer for the project planning. Project planning consists of five basic steps such as conception, feasibility of work, design, construction and maintenance. Following works are done under the guidance of civil engineer.

1. Surveying.

For planning all developmental activities, proper maps are required. The science of map making is known as surveying. Survey maps provide the relative positions of various objects of the area in the horizontal as well as vertical directions. Earlier conventional instruments like chain, tape, compasses, theodolites and levels were used for various measurements in surveying. In this electronic era the modern equipments like electronic distance meters and total stations are used for measurements. Modern technology like remote sensing has made surveying vast area in a short period possible.

2. Drawing

Drawing is the language of engineers. The survey maps and plans, the building descriptions etc. are to be provided with neat scaled drawings.

3. Estimation and Specification

Civil engineers have to prepare estimation and detailed specifications for each and every work in the assigned project.

4. MANAGEMENT TECHNIQUES

Civil engineers must manage, men, materials and equipment of the project. As large amount has to be spent for civil engineering projects, a civil engineer must know the basics in financial management and legal aspects/obligations. Knowledge of management techniques is an asset to practicing civil engineer. By adopting proper management technique the project cost can be reduced considerably.

5. COMPUTER APPLICATIONS

The magnitude of designing the structures and storing information is very large compared to few years back, civil engineers must go for computer applications. AutoCAD drawings are produced using computers. There are a good number of civil engineering software for the design of structures, thus we can maintain accuracy and save time for doing design and drawing plans/maps.

1.3. PLANNING

Planning is one of the important part of a project or assignment. For the successful finishing of a project, planning is essential. From experience it is clear that for the successful completion of a work, planning is essential.

Advantages of planning

- i. It minimises uncertainties like availability of work man, equipment, raw materials etc by planning alternate arrangements.
- ii. Proper planning gives good control over the work.
- iii. Optimum usage of manpower and material is possible.
- iv. Planning help to achieve the objectives in the targeted time.
- v. Planning leads to the overall success of the project.
- vi. Overall project cost can be saved considerable.
- vii. It exercises good control

With proper planning there is optimum use of materials and man power, which result in cost reduction in construction industry. There will be good control on every wing of the construction activity. Cashflow for the activity is streamlined avoiding unnecessary holding of the funds or hampering of the work due to cash shortage. Hence planning is necessary for exercising good control on the construction work..

PLANNING FOCUSES ON OBJECTIVES.

A construction industry may have an objective of specializing itself in irrigation projects, road projects, building construction, producing precast products etc. It has equipment and expertise in achieving particular objectively. Planning helps the managers of all department to work for achieving the objective, periodically revise the plan in the interest of achieving the objective.

PLANNING LEADS TO SUCCESS.

Planning, Scheduling and Management form the corner stone for any construction activity. Even though discussion here is about construction, the same principles hold good for any work/organization. Planning is the decision-making process about What, Where, Who and How (WWWH) to start a project.

What: An individual or a group of enterprising people plan to start a project. They form a group of high level managers. They identify goals, frame the objective and identify opportunities. The planning done by them may be called as strategic planning.

Where: The strategic planners decide the time and the place of starting the organisation.
Who: The strategic planners identify the middle level managers and operational level planners to carry out the task. The middle level management deals with financial management and coordinates with operational planners and strategic planners.

How: The planners have to work at minute details of the work assigned, find the requirement of machinery and work force and plan day to day activities. They should be ready with alternative plans, if uncertainty occurs at any stage of the work.

1.4. ESTIMATION AND DETAILED SPECIFICATION

Civil engineers have to prepare estimation and detailed specifications for each and every work to be taken up. By this it is possible to identify the quantity of earth work, concrete required for foundation, bricks needed for construction etc.

For example, if the project is to design of a dam in Pampa river. Then we have to think about where to locate the dam. If we construct one dam, water level on the upstream side of the dam rises and we have to evacuate the people living in that area to a new place. So the submerged area should be less and should not be a thickly populated area. And the soil and geographical nature of the land must be capable of accommodating a dam. This process is normally performed by a team. In the conception stage there may be many answers to the problem and we have to select three or more options based on theoretical studies.

Next we have to study the feasibility of the selected options. Feasibility study consists of a series of steps by which all out come of each selected site were crossly watched and cut off the selected options into two. A second detailed study is then made to select the best of these two options so that environmental impact of the dam is minimum and that can be managed by the technology. Thus you can select the location of dam, proposed length of dam, how much is the height and maximum design water level, and the areas of land submerged due to increase in water level. How much people and houses will be affected by the construction of such a dam, and the ecological impact of the project. Find out the solution to manage the environmental impact.

Next step is the design part. Here the structure is dam so what are the forces expected to act on the dam: mainly water pressure, uplift pressure of water on the floor, wind pressure and self weight of the dam. Design is an iterative process by which we have to calculate the bottom width of dam, height of dam, slope of faces of dam, material to be used for the construction of dam. The design process is divided into two (i) Preliminary design and (ii) detailed design. In preliminary design dimensions and quantities of materials are roughly analysed and calculate the estimate. Drawings are also prepared to get the approval of the approving authority. But in detailed design report all calculations, size of structures, foundation details, material selection and position of reinforcement etc are to be mentioned clearly, so that the workman can do the work easily.

After the preparation of detailed design report construction work can be started. Civil Engineer's role in construction work is supervision i.e. to check whether the work is as per plan and detailed design report, check measurements are correct, provide technical advice for the workers while mixing of concrete, placing of reinforcement and mode of construction etc. Last step in any project is the maintenance and proper maintenance will improve the efficiency of project.

1.5. SUB-DISCIPLINES OF CIVIL ENGINEERING

(1) STRUCTURAL ENGINEERING



Fig . 1.1 Building Structures

All structures, regardless of their function, are subjected to forces caused by the natural environment (such as wind and earthquakes) and by man (such as cargo and automobile traffic), and they must be designed to withstand these two modes of forces. These structures can be as varied as buildings, bridges, pipelines, dams, retaining wall, stadiums and spacecrafts. The job of the structural engineer is to create new designs or to evaluate and improve the load resistance capabilities of existing structures which may have been damaged during an earthquake or heavy wind. In order to accomplish these the structural engineer must be knowledgeable about the behavior of load, about its sources, magnitudes and occurrence of applied loads, material properties, design philosophies, governmental design codes, and about computer aided design and usage.

(2) CONSTRUCTION MANAGEMENT

The ultimate product of every civil engineer's work is a constructed facility. The construction industry accounts for 15 out of every 100 jobs in the country and consumes more basic and finished materials than any other industry. Civil engineers are responsible not only for the design of complex engineering systems but also use both technical and management skills to plan and build structures. For this they must apply the knowledge of construction methods and equipments along with principles of planning, organizing, financing, managing, operating the construction enterprises.

The construction of a highway, a power plant, a concrete dam, or an office building requires an in-depth understanding of economic principles, design fundamentals, material properties and management techniques. Civil engineers play a vital role in constructing facilities that directly affect our national prosperity and the overall quality of life.

(3) GEOTECHNICAL ENGINEERING

Geotechnical Engineering involves several interrelated subdisciplines. Soil mechanics includes soil technology, soil testing techniques, and methods of modifying soil properties. Pavement Materials engineering involves the characterization and behavior of construction materials under various environmental and load conditions.

Geotechnical Engineers design footings, raft foundations, piles and pile bents, pier earth retaining structures, shoring, and the underpinning of structures. They also design dams, solid waste landfills and wetland dewatering systems. They work closely with Environmental Engineers in the areas of solid waste management and groundwater protection.

(4) PUBLIC WORKS ENGINEERING

In urban and community development planning, civil engineer's role is very important. They develop street patterns for facing the demand of people, location of park, recreation area, areas for residential purposes, industrial purposes, schools, colleges, hospitals etc. Research in the public works engineering program has been concentrated in the management, planning, administration, safety, and engineering aspect study of public works infrastructures. The main concern in this area is that many public works facilities have not been adequately maintained and managed and may cause risks to public health and safety.

States, cities and districts around the world conduct daily public works activities to allow urban complexes to function efficiently. It is the responsibility of public officials to properly maintain the streets, promote traffic safety, provide storm drains, prevent flooding, provide potable water, transport liquid waste to treatment facilities, transport and store hazardous waste, collect and dispose of solid wastes, design and install traffic-control facilities, etc. For solving these, following is to be done: data collection, management, planning, communication, purchasing, finance, personnel and interpersonal relations, legal aspects, etc.

(5) TRANSPORTATION ENGINEERING

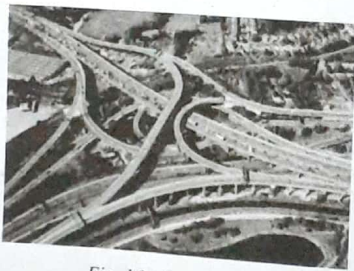

Fig 1.2 Road network

The transportation system is a basic component of any area's physical, economic, and social

structure. Not only does the design and performance of the transportation system provide opportunities for mobility; but over the long term, it influences patterns of growth and the level of economic activity through the accessibility it provides the land. The field of Transportation Engineering focuses on the planning, design, construction, and management of transportation systems such as roads, railways, airports, highways and traffic control signals.

These systems consist of the facilities, vehicles, control mechanisms, and the policies that combine to permit the efficient conveyance of people and goods. Designs highway systems (layout, routing), pavement material, airport runways, rapid transit projects. Also involved in computer control of traffic signals.

(6) WATER RESOURCES ENGINEERING AND IRRIGATION ENGINEERING



Fig 1.3 Dam

Water management involves the use of hydrologic and hydraulic principles to design, drainage system, detention pond, navigational water ways, flood control structures, dams and lakes. Water resources engineering usually deals with the application of fluid mechanics principles to water flow problems. Engineering hydrology quantifies the distribution and movement of water in the environment. Some problems encountered in water resources engineering include: floods, sediment transport, water supply, wave forces, hydromachinery, and the protection or restoration of surface and ground water resources.

Engineers in the hydraulics/hydrology area may spend their time with applied mathematics, laboratory experimentation, or field construction and testing. The skills necessary range from imagination and common sense to sophisticated analytical and computer modeling ability. Irrigation Engineering deals with the water management for agricultural activities.

(7) SURVEYING

Surveying is the process by which a survey or measures certain dimensions that generally occur on the surface of the Earth. Modern surveying equipment, such as EDM's, Total Stations, GPS Surveying and Laser Scanning, allow for remarkably accurate measurement of angular

deviation, horizontal, vertical and slope distances. This information is crucial to convert data into a graphical representation of the Earth's surface, in the form a map. This information is then used by Civil Engineers, Contractors and even realtors to design from, build on, or trade, respectively. Elements of a building or structure must be correctly sized and positioned in relation to each other and to site boundaries and adjacent structures. Civil engineers are trained in the methods of surveying and may seek Professional Land Surveyor status.



Fig 1.4 Surveying

(8) ENVIRONMENTAL ENGINEERING

Environmental engineering deals with the treatment of chemical, biological, and/or thermal waste, the purification of water and air, and the remediation of contaminated sites, due to pollution, waste disposal or accidental contamination. Among the topics covered by environmental engineering are pollutant transport, water purification, sewage treatment, and hazardous waste management. Environmental engineers can be involved with pollution reduction, green engineering, and industrial ecology. Environmental engineering also deals with the gathering of information on the environmental consequences of proposed actions and the assessment of effects of proposed actions for the purpose of assisting society and policy makers in the decision making process.

Environmental engineering is the contemporary term for sanitary engineering, though sanitary engineering traditionally had not included much of the hazardous waste management and environmental remediation work covered by the term *environmental engineering*. Some other terms in use are Public Health Engineering and Environmental Health Engineering.

We engineers must think seriously about how to construct building that feel good for occupants but also how to do so without adverse effect on workers involved in construction and the environment. Important things are how construction materials influences the room climate and impact on environment ie how plants and animals are influenced by discharge caused by

production and disposal of such materials. The number of sick building has increased with time, those who spend time in these buildings shows one or more of the following symptoms: eye/nose/throat irritation, throat infection, sinus infection, dryness in mucus membrane, dry lip and skin, itchy face and scalp, skin redness, eczema, fatigue, lack of concentration, headaches and allergy problems.

(9) ENGINEERING RESEARCH

The role of the research engineer is achieved after many years of study. Most colleges and universities offer research sub-discipline in the Civil Engineering. Students should choose courses which they wish to specialise in any of the above area for finding new technologies for reducing the energy consumption, increasing comfort of inmates at the same time the structure should be environment friendly. Research should be oriented for the protection of our environment from the impacts that we already made to earth and atmosphere. Think about the solutions for preventing pollution created by a new project that we planned and implement it before running the project. Think for a green world with all positive energy to welcome the new generation. Do what we can do for that.

Examples

1. Write the relevance of Civil Engineering in the Infrastructural Development of the country?
2. What is the role of Civil engineering in the infrastructural development.
3. Write the impact of infrastructural development of a country.
4. Write short note on impact of infrastructural facility on socio-economic growth of a Nation.
5. What is the responsibility of an Engineer in ensuring the safety of Environment.
6. Write short note on sub disciplines of Civil Engineering.

BUILDINGS

2.1 INTRODUCTION

Building is a structure, which provides shelter to mankind. It is an enclosed space by walls, floor and ceiling. These enclosed spaces are called rooms. Depending upon the utility of rooms, they are classified as living room, dining room, bathroom, store, kitchen and latrine. Civil engineers design the various components of the building such as slabs, beams, columns, etc and place the building in a particular direction and arrange the rooms of building to get maximum comfort from natural sources.

2.1.1. Classification of building : According to National Building Code buildings are mainly classified on the basis of (i) occupancy, (ii) fire resistance capacity, (iii) height of building, (iv) mode of load transfer and (v) type of material used for construction.

(i) Based on occupancy, buildings are classified into nine groups

- | | | |
|-------------------------|--------------------------|---------------------------|
| a) Residential building | b) Educational building | c) Institutional building |
| d) Assembly building | e) Business centre | f) Mercantile building |
| g) Industrial buildings | h) Storage building | i) Hazardous buildings |
| j) Government building | k) Agricultural building | l) Religious building |

a. Residential Buildings : These shall include lodging or rooming houses for one or two family, private dwellings, Dormitories, Apartments(Flats), Hotels, flat, villas etc.

b. Educational Buildings : Building used for schools, college or day care purposes for more than eight hours per week involving assembly for instructions, educations or recreation

c. Institutional Buildings: These shall include any building or part thereof which is used for purposes such as medical or other treatments or care of persons suffering from physical or mental illness or diseases or infirmity, care of infants, convalescents of aged persons. Institution building ordinarily provide sleeping accommodation for the occupants. Examples of this type of building are hospital, sanatoria, nursing homes, orphanages, jail, prison, mental hospitals etc.



Apartment Villa Library

Fig 2.1. Residential Building and Rducational Building

d. Assembly Buildings : These shall include any building or part of a building, where groups of people assemble or gather for amusement, recreation, social, religious, patriotic, civil, travel and building for similar purposes etc. Examples of this type of building are Assembly hall, Theatres, auditorium, exhibition halls, gymnasiums, restaurants, club rooms, museums, religious building like church, temple and mosque, Transit stations like Air ports, railway Stations, Bus stations,

e. Business Building : These shall include any building or part of a building, which is used for the transaction of business; for the keeping of accounts and records and similar purposes; Court houses, libraries can be included in this group since the main function of these two buildings are for the transaction of public business and then for keeping of books and records.

f. Mercantile Buildings: These shall include any buildings or part of a building which is used for display and sale of merchandise such as shops, stores, market either for whole sale or retail. Banking and financial institutions, professional establishment of doctors, dentist, engineers, architects, lawyer comes under this group.

g. Industrial buildings:: These shall include any building or part of a building or structure, in which products or materials of all kinds and properties are fabricated, assembled or processed. Example : Refineries, assembly plants, dry cleaning plants, pumping stations, laboratories, gas plants, laundries. Mills, diaries, etc.

h. Storage building : These shall include any building or part of a building primarily for the storage or sheltering of goods(including servicing, processing or repairs incidental to storage), wares or merchandise (except those that involve highly combustible or explosive products or materials), vehicle or animal. Examples of this type of buildings are warehouses, cold storages, freight depots, transit sheds, store houses, truck and marine terminals, garages, hangars etc.

i. Hazardous Buildings: These shall include any building or part of a building which is used for the storage, handling, manufacture or processing of highly explosive materials or products which are liable to burn with extreme rapidity or may produce poisonous fumes or explosions.

j. Government buildings: The building which function as a part of Government, eg. Fire station, secretariat, prison, embassy, post office, etc

k. Agricultural building: These are buildings designed for farmers and for agricultural practices, for growing and harvesting crops, and to raise live stock.

l. Religious building: These are the buildings for religious purposes, with a large open interior or other monumental qualities. They often have spires, towers, domes rising above the main structure.



Church Fire station Cow shed

Fig 2.2. Religious Building, Government and Agricultural Building

(ii) Based on fire resistance capacity of building: Building shall be classified into four categories such as Type 1 construction, Type 2 construction, Type 3 construction and Type 4 construction.

a. Type 1 construction – Type 1 constructions are fire proof constructions in which all the structural components are incombustible and should be fire resistant for four hours.

b. Type 2 construction – In Type 2 constructions all the structural components are made of incombustible materials and it should be fire resistant for three hours

c. Type 3 construction – In Type 3 constructions exterior portion constructed with incombustible structural components and the inner parts other than inner walls made of combustible material. It should be fire resistant for two hours.

d. Type 4 construction – In Type 4 construction exterior walls, bearing walls roof and floor constructions wholly or partly of wood or other combustible material. It should be fire resistant for one hours..

(iii) Based on height of construction, buildings are classified into two groups

a. High rise Building : Building with height greater than 15m.

b. Low rise Building : Building with height less than 15m.

(iv) Based on mode of load transfer, buildings can be classified into two types.

a. Load bearing masonry building: In which load of upper floors and lower floors are transferred through the masonry wall. And they transfer this load to the foundation.

b. Framed building: In this type of building framework of columns and beams designed to carry over the load to foundation.

(v) Based on predominant materials used for construction buildings are classified into six groups

- | | |
|---------------------|----------------------|
| a. Earthen Building | b. Thatched Building |
| c. Masonry Building | d. Wooden Building |
| e. Steel Building | f. RCC Building |

(vi) Classification of building based on NBC

1. Group A : Residential building - lodging, dwelling, dormitories, flats, hotels
2. Group B : Educational building - schools, colleges, recreations
3. Group C: Institutional building - hospitals, homes for aged, orphanages, jails, mental hospitals.
4. Group D: Assembly buildings-theatres, drama hall, Assembly hall, Auditorium, restaurant.
5. Group E: Business buildings- office, lab, computer installations.
6. Group F: Mercantile building- shops, stores market.
7. Group G: Industrial building- Assembly plants, labs, pumping stations, refineries
8. Group H: Storage building- all types of storages, garages, hangers, sheds, stables etc.
9. Group I: Hazardous buildings- used to store combustible, poisonous/ toxic materials.

2.1.2. Planning of a building

The first step in planning of a building is to decide the plinth area of the building

$$Plinth\ area\ of\ a\ building = \frac{Available\ funds}{Plinth\ area\ rate\ of\ similar\ building\ in\ that\ locality}$$

Plinth area rate can be calculated by dividing the total cost of similar building recently constructed in the locality by the plinth area of those building. Available floor area (carpet area) is about 80% of plinth area. This floor area can be divided in to various rooms on the basis of our requirements, and standards specified by the local authority. In a residential building floor area can be divided in to living area (drawing room, sit out, T.V. room etc.); sleeping area (bed

room, guest room); service area (kitchen, dining room, office room, toilet, bathroom etc.) and other area like staircase, prayer room, lobbies etc.

2.1.3. Main parts of a building

A building essentially consists of two parts, namely the super structure, which is above the ground level and substructure, or foundation, which is below the ground level. Foundation is the part of a building, which transfers the entire load of the building to the subsoil.

Plinth: The portion of the building below the ground floor level and above the level of the ground, is called plinth. The top level of the plinth is called plinth level. The plinth height should be such that after proper leveling of the ground around the building, there should not be any possibility for the rain water to enter the ground floor. Built up covered area at the floor level of the building is known as the *plinth area*.

Doors: Doors are the openings provided in walls of a building to connect the internal rooms and also used as a means of free movements inside and outside of the building.

Windows and ventilators: Windows are opening provided in the outer walls of building for the entry of light and air into the room. Ventilators are openings provided in the outer walls for the escape of foul gases from rooms. Ventilators are provided on the top of walls i.e. very near to roof level. Windows are provided below the door level i.e. top level of doors and windows are at same.

Walls: These are vertical components constructed to divide the space into various rooms. Walls transfer load of roof and live load above it to the foundation.

Column: A column may be defined as an isolated vertical load bearing member. And its width should not be less than its thickness and it should not be greater than four times its thickness.

Pier: Pier is a vertical load bearing member similar to column, except that it is bonded to a load bearing wall at the side to form an integral part of wall and it extends to the full height of the wall. Usually a pier is constructed to increase the stiffness of wall to carry additional vertical concentrated load.

Lintels: Lintels are reinforced cement concrete structures provided over the opening such as doors, windows, etc. and are used to transfer the load of wall above the opening to the supporting wall on either side of opening.

Sunshade: The slab projecting from the external wall just above the doors, windows, ventilators, etc. are called sunshades. It protect doors and windows from direct sunlight and rain.

Floors: Floors are horizontal surfaces, which divide a building in to different levels and over which the occupants of the building move about. The floors provided on the top of the buildings are called first floor, second floor, etc. depending upon their relative position.

Sub-floor is the structural part of the floor which supports all the loads and the flooring material like marble, tile, mosaic etc are provided over this sub floor as a finishing layer.

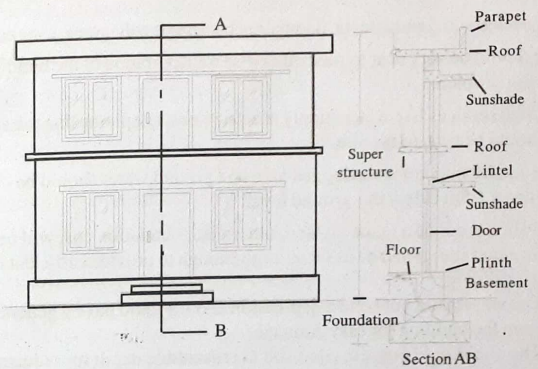

fig. 2.3 Building

Basement floors: They are floors of room below the ground level.

Roofs: The top most part of a building, which covers the space enclosed by the wall, is called roof. Main two components of roof are *roof decking* and *roof covering*. Roof decking is the structural part which supports the roof covering.

Stairs: These are structures used to climb from one floor to another. Stairs consists of a number of steps. Height of step is 15 cm and width of step varies from 25 to 30 cm.

Partition: An interior non-load bearing wall of full wall height or part storey height used for dividing floor area into different sections.

Parapet: These are structures constructed over the roof slab or sunshade for better appearance of building and for safe usage of roof surface.

2.2 SELECTION OF SITE FOR BUILDINGS :

The first and foremost step in construction is to select an appropriate site for the building. A properly selected site of the building will increase the beauty of building without any extra expense. The selection of site for a project depends upon the purpose of building, mode of construction, available fund, future development if any required, accessibility from road, school, hospital etc. In case of marshy land or water logged area we have to spend

more money for the construction of foundation and there is chances of settlement if the building is not properly designed.

The following points are to be considered while selecting the site for any building:

- (i) Selected site should not be undulating because it will increase the cost of leveling.
- (ii) It should be very near to road otherwise transportation of the building material is a big problem.
- (iii) Civic services like water supply, electric lines, telephone lines, drainage sewers should be near to the site.
- (iv) It should not be a waterlogged area and ground water should be atleast 1.5m below the ground level.
- (v) It should not be a made up land, otherwise foundation cost will be high.
- (vi) Selected site should be as far as large enough to provide sufficient light and air to the building.
- (vii) The site should not be in a depression and it should have a general slope away from the building for easy drainage.
- (viii) The site should possess good soil at reasonable depth for reducing the cost of foundation.
- (ix) The selected site should have adequate space to accommodate all the essential accessories required in the building.
- (x) Site should not be located near workshop and factories since such locations are subjected to noise/air pollution.
- (xi) Site along seashore is good from the entertainment point of view but sea breeze is not good for health and it may also lead to corrosion of metal fittings.
- (xii) Type of building also affects the selection of site. For example Industrial building should be situated outside the city, residential building must be near to Schools & hospitals, and public building should be located in an open area so that all the requirements should be fulfilled.
- (xiii) For industrial building selection of site should be such that:
 - (a) All most all raw materials should be available from the nearby areas.
 - (b) There may not be any problem for labour and labourers should be available from near by area.
 - (c) The site must have enough space for future expansion of industry and for the construction of residential area for workers.
 - (d) Suitable disposal plant to treat waste produced must be available at reasonable distance.
 - (e) Climate plays an important role in selecting the site for industrial buildings. For example, a cool and moist weather is more favorable for weaving and textile mills.

2.3. BUILDING RULES

Building Rules and bye laws are laid down by the Municipal or Town Planning Authorities for framing public or private building. Government of India has published National Building Code (NBC) for a reference for local bodies in framing building rules. In Kerala, planning and construction of building are governed by the Kerala Municipal Building Rules (KMBR). Important rules and regulations of NBC are described below:

- (a) General requirement regarding plots.
- (b) Exterior or interior open spaces.
- (c) Built up areas of buildings, coverage and floor area of building.
- (d) Where a building is newly erected, the building rules of KMBR shall apply to the designs and construction of the building.
- (e) Where the building is altered, the rules in KMBR shall apply to the altered portion of the building
- (f) Where the occupancy or use of building is changed, these rules shall apply to all the parts of the building affected by the change.
- (g) Size, height and ventilation of rooms.
- (h) Water Supply, sanitation and rainwater harvesting.

2.3.1 General rules for selection of building plot as per NBC

- (1) Building should not be constructed on any plot where there is deposit of refuse, excreta or other offensive matter.
- (2) Building should not be constructed on a plot, which consists of big pit / quarry.
- (3) Building should not be constructed on a plot liable to flood or on a slop forming an angle of more than 45 degrees with horizontal.
- (4) Building construction or reconstruction in any area notified by the Government of India as a coastal regulation zone is restricted.
- (5) Building should not be constructed with a minimum clearance from the over head electric supply line as described below:

2.3.2. Exterior and Interior Open space around building :

Exterior Open space around building of height upto 10m is as follows

- i. Building should have a front yard of minimum width 3m and side yard 1.5m. . If its two sides face a street, width shall be 3m average but not less than 1.8m
- iii. Building shall have a rear open space of average width 3m and should not be less than 1.8m at any place.

For heights of buildings between 10 and 25m, the minimum open space shall be increased at the rate of 1m for every 3m increase in height above 10m. For heights above 25m there shall be a minimum open space of 10m and for heights above 30m, this shall be increased

at the rate of 1m for every 5m increase in height and subject to a maximum of 16m.

$$\text{Floor Area Ratio (F.A.R.)} = \frac{\text{Covered area of all floors} \times 100}{\text{Plot area}}$$

Plot Area is the area which is enclosed by the boundaries of the plot. Covered area is the maximum floor area of the building after excluding the cantilevered open balconies, garden, compound wall, gates, uncovered staircase etc.

Carpet Area is the usable floor area excluding stair cases, lift wells, ducts, toilets, electrical and airconditions, plant rooms etc.

For residential building permissible FAR is 3.0 Plot Area is the area which is enclosed by the boundaries of the plot. Covered area is the maximum floor area of the building after excluding the cantilevered open balconies, garden, compound wall, gates, uncovered staircase etc.

2.3.3. Coverage and floor area ratio as per NBC

Sl.No.	Building Use	Max. Coverage %	Max. Permissible F.A.R
1.	Residential	60	15
2.	Educational	30	12
3.	Commercial	60	20
4.	Industrial	40	12
5.	Office Building	40	15
6.	Assembly	40	0.7

2.3.4. Minimum requirement of room spaces:

The heights of all rooms for human habitation shall not be less than 2.75m from surface of floor to lower part of ceiling or bottom of slabs, provided that the minimum head room at any point in the room shall not be less than 2.4m.

The size of a habitable building shall not be less than 9.5m² where there is only one room. Where there are two habitable rooms one shall not be smaller than 9.5m² and the other not less than 7.5m². Minimum width of room shall not be less than 2.4m.

The height of kitchen shall not be less than 2.75m and the area not less than 5.5m² with a minimum width of 1.8m. Where there is a separate store 4.5m² kitchen area is enough. If the kitchen is used as a dining cum kitchen, area shall not be less than 9.5 m².

Every habitation room shall be furnished with sufficient number of openings such as windows, ventilations and air holes to provide sufficient light and air circulation. In case of kitchen in addition to ventilation and lighting, provision should be provided for the escape of smoke and heated air.

Height of bath room or water closet (w.c) shall not be less than 2.2m. Size of bath room shall not be less than 1.5m x 1.2m or 1.8m². For combined bath room and w.c. area should not be less than 2.8m². Minimum area for w.c. is 1.1m².

2.4. SITE PLAN

The detailed sketch of the plot with the sketch of proposed building and necessary surrounding data is called a site plan. Site plan should be drawn to a scale not less than 1:1000 showing the following details:

- (i) Boundaries of the plot with revenue survey details.
- (ii) Location of the plot in relation to the main street and its access.
- (iii) All the existing structure immediately outside the plot with details of access, set back etc.
- (iv) North direction should be marked in the site plan.
- (v) Lay out of the proposed building and topographic contours to be marked in the site plan.

While preparing the site plan the clearance of building from the boundary and near by road should be as insisted in the National Building Rule/ Kerala Municipality Building Rules.

For the preparation of site plan of a building in a rectangular plot of size 30mx36m, which is located 20m away from the Vazhaila junction and on right side of the state highway Perorkkada to Nedumangad, one bank building is functioning just on the opposite side of the proposed plot. Survey number of the plot is 11/30. Front clearance of the building from the boundary is 4m, back clearance 2m, right and left side clearance is 3m and 2m respectively. Length of building 25m and width 30m with clear size and shape to be marked in the site plan as shown in the fig 2.4

North direction of the site to be marked in the site plan for getting an idea about the direction. Survey number of near by plots to be marked in the site plan. As a first step mark the position of important roads near the site with approaching road to the location with scale of drawing as 1:1000. Fix the position of proposed plot and building. Second step is to mark the position of important structures around the building and clearance of proposed building from boundary.

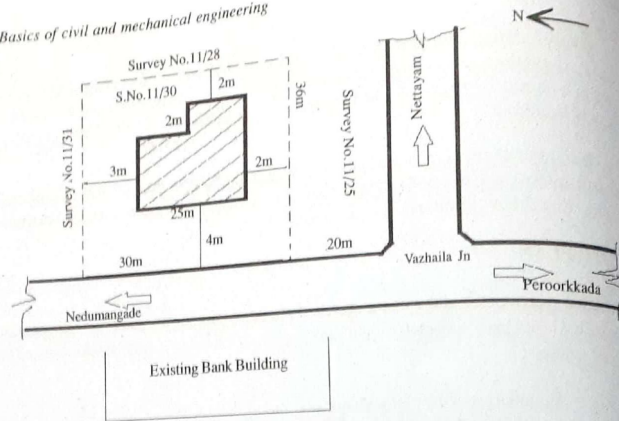

Fig 2.4 Site Plan of a building

2.5. SETTING OUT OF BUILDING

The process of marking the position of building on the selected site is called setting out of the building. For setting out the foundation lines, the engineer has to prepare a foundation plan to a convenient scale with all the measurements and then transfer these lines to ground. The setting of building on the ground may be done by centre line method.

Steps in centre line method are: Mark out one long line of indefinite length by stretching a string between two wood pegs at ends. Usually it is the centre line of one of the longest outer wall. Set out centre line of all other walls with reference to the first, either perpendicular, parallel or at any angle as in foundation plan. If a rectangle is set out, its correctness can be checked by measuring the diagonal from opposite corners. The corner reference pegs are driven sufficiently outside the foundation excavation i.e. about one metre from the outer edge of foundation trench as in fig 2.5.

For systematic setting of building, platform of brickwork in lime mortar of 15cm wider than the foundation trench and at least 60cm away from the outer edge of foundation excavation (refer fig. 2.6). These pillars are known as reference pillars. Exact location of the centre line marked on the reference pillar by means of nails. Similarly mark the width of foundation symmetrically on either side of centre line by means mason's trowel as shown in figure.2.6

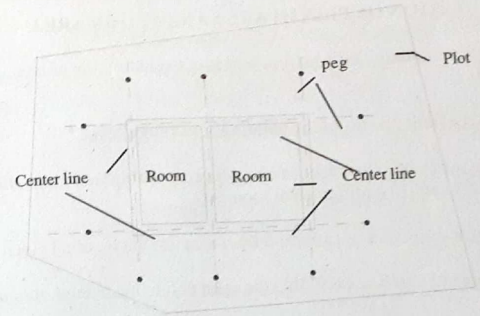

Fig 2.5 setting out of buildings using reference pillar

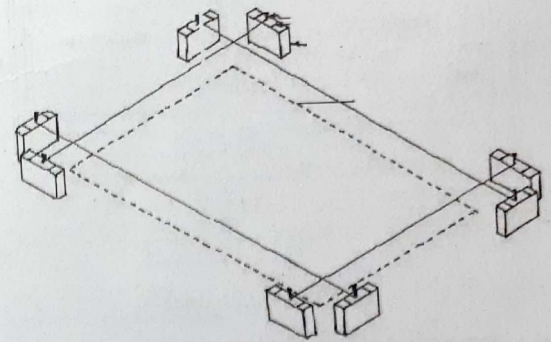

Fig 2.6 Plan of a building

Strings should be stretched along the marks of foundation width in reference pillar. Lime powder may be used for marking the outer lines of foundation trench on the ground. The masonry work of foundation or plinth can be checked at any time by stretching a string along the lines marked on the reference pillar, thus saving the time and labour for checking with a spirit level.

2.6. COMPUTATION OF PLINTH AREA AND FLOOR AREA

Plinth area of a building is the area of building excluding the open porch, uncovered stair case etc.

Floor area is the built up area of the building at any floor level.

Carpet area is the usable floor area of a building excluding stair cases, lift wells, ducts, toilets, electrical and aircondition plant rooms etc.

Calculate the plinth area, carpet area and floor area for the building given in fig 2.7

Plinth area = area of building excluding the open porch, uncovered stair case.

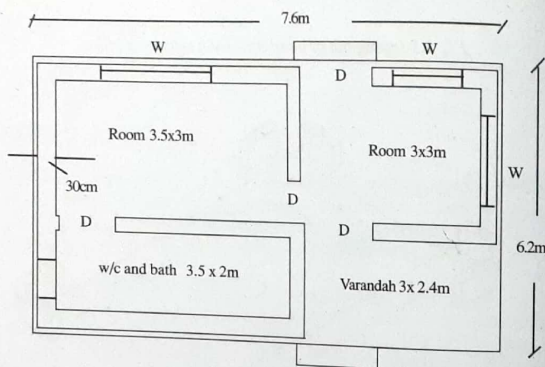

Fig 2.7 Plan of a building

In this case no open porch or stair case hence plinth area =
= outer length of building x outer width of building

$$\begin{aligned} \text{Plinth projection} &= 0.1\text{m} \\ \text{Plinth area} &= 7.6 \times 6.2\text{m}^2 = 97.12\text{m}^2 \\ \text{Floor area} &= \text{Plinth area} - \text{area occupied by walls} \\ \text{Area occupied by walls} &= (2 \times 7.4 \times 0.3) + (3 \times 3 \times 0.3) + (2 \times 2 \times 0.3) + (4.1 \times 0.3) \\ &= 11.57\text{m}^2 \end{aligned}$$

$$\begin{aligned} \text{Floor area} &= 85.55\text{m}^2 \\ \text{Carpet area} &= \text{Floor area} - \text{Non-usable area.} \\ \text{Floor area of Verandah} &= 3 \times 2.4 = 7.2\text{m}^2 \\ \text{Area of w/c and bath} &= 3 \times 2 = 7.0\text{m}^2 \\ \text{Carpet area} &= (85.55 - 7.2 - 7.0) \\ &= 71.35\text{m}^2 \end{aligned}$$

$$\text{Floor Area Ratio Building} = \frac{\text{Covered area of all floors} \times 100}{\text{Plot area}}$$

If area of plot is 450 m^2

$$\text{Floor area ratio of Building} = \frac{85.55 \times 100}{450} = 0.19$$

2.7. COASTAL REGULATION ZONE (CRZ).

Coastal zone is the area of interaction between land and sea, which is influenced by both terrestrial and marine environment. It includes the area between high tide and low tide up to 10 nautical miles towards the sea from the high tide line and up to 20km from high tide line towards the land side. Due to high rate of human population growth, development of industries, fishing, discharge of municipal sewage, industrial waste disposal leads to degradation of coastal ecosystem and an abrupt decrease in coastal resources. Ministry of Environment and forest, Government of India issued a notification in the year 1991, under Environment protection Act of 1986, declaring coastal stretches up to 500m from the High Tide line and a stage of 100m along the bank of estuaries, backwater and rivers affected by tidal fluctuations is called coastal regulation zone.

India has a coast of about 7516km long and 4198 islands are spread along the main coast. Kerala has a coast length of about 580km.

Coastal area classification and development

For regulating developmental activities the coastal stretches within 500m of high tide line on the landward side are classified into the following four categories of Coastal Regulation Zone CRZ-1, CRZ-2, CRZ-3, CRZ-4.

CRZ-1: The area that is ecologically sensitive and important / essential for maintaining the ecosystem of the coast. They lie between low and high tide line. Exploration of natural gas and extraction of salt are permitted

CRZ-2: The area that are already been developed up to and close to the shore line. They are urban areas located in the coastal areas with road network, water supply, sewerage system and other infrastructure facility.

CRZ-3: The area that are undisturbed under rural and urban localities which fall outside the 1 and 2. Only certain activities related to agriculture even some public facilities are allowed in this zone.

CRZ-4: This area lies in Andaman Nicobar, Lakshdweep and are not included in CRZ-1 or 3. Fishing and allied activities are permitted in this zone. Solid waste should be let off in this zone.

Tourism infrastructure for basic amenities to be promoted: Temporary tourism facilities such as shacks, toilet blocks, change rooms, drinking water facilities etc. have now been permitted in Beaches. Such temporary tourism facilities are also now permissible in the "Development Zone" (NDZ) of the CRZ-III areas as per the Notification. However, a minimum distance of 10 m from HTL should be maintained for setting up of such facilities.

Exercise

1. What are the various components of a building ?
2. How can you classify buildings ?
3. What are the steps involved in the selection of site for building ?
4. What are the space requirements of a building ?
5. List the steps in the setting out of foundation in centerline method.
6. What are the main rules to be followed for building construction?
7. Write short note on site plan of a building.
8. Define plot area, plinth area, floor area and carpet area.
9. Write short note on various disciplines of Civil Engineering.
10. What is meant by planning? What are the advantages of planning a project?
11. As per NBC what are the rules for selecting a plot for residential building?
12. What is meant by CRZ (Coastal regulation Zone)?

CONSTRUCTION MATERIALS

3.1 INTRODUCTION

Materials used for the construction of building are stone, brick, cement, aggregate, timber, steel, glass, plastic pipe etc. Safety of a building depends on the quality of material used for construction, design of building and the workmanship involved in the project.

3.2 STONE

Stones are used as building material since prehistoric ages. Stones which are heavy, dense, durable and strong can be used as construction material.

3.2.1. CLASSIFICATION OF ROCKS:

Rocks can mainly be classified into three types :

- a) Geological b) Physical c) Chemical

(a) **Geological Classification:** According to this classification there are three types of rocks

- (i) Igneous rock (example granite, Basalt)
- (ii) Sedimentary rock (Sand stone, shale, lime stone, laterite) and
- (iii) Metamorphic rock (Quartzite, slate, marble, gneiss).

(b) **Physical classification:**

Based on the structure of rock it can be classified into

- (i) Stratified rock (ii) Unstratified rock and (iii) Foliated rock

(c) **Chemical classification:** This classification is sometimes known as scientific or engineering classification. According to this, there are three types of rocks.

- (i) Siliceous rocks (ii) Argillaceous rocks and (iii) Calcareous rock

3.2.2. QUALITIES OF GOOD BUILDING STONE:

- a. Crushing strength should be greater than 1000kg/cm²

- b. They should preserve their colour uniformly for a long time.
- c. They should be durable
 - d. Hardness should be greater than 17
 - e. Percentage wear should be less than 3%
 - f. Specific gravity should be greater than 2.7
 - g. Toughness index should be greater than 19
 - h. Water absorption should be less than 0.6
 - i. It should possess good fire resistance property.
 - j. It should not contain any soluble matter.
 - k. It should possess good facility for carving
 - l. It should have fine compact crystalline structure free from cavity and or patches of soft or loose materials.
 - m. It should be well seasoned before use (6 to 12 months).
 - n. Percentage crystallisation should be less than 2%.
 - o. It should possess good appearance.

3.2.3 TEST FOR STONES:

For testing different properties of stones following tests conducted:

- | | | |
|-------------------------|------------------------------|--------------------------|
| 1. Acid test | 2. Attrition test | 3. Crushing test |
| 4. Crystallisation test | 5. Freezing and thawing test | |
| 6. Hardness test | 7. Impact test | 8. Water absorption test |

1) **Acid test:** Acid test is used for testing the durability of stone. For conducting this test, take a sample stone weighing about 50gm to 100gm. Place this sample stone in a solution of hydrochloric acid of strength 1% and it is kept there for seven days. The solution is agitated at intervals. A good building stone should maintain its sharp edges and it should be free from any powder formation at the end of the period. If edges are broken and powder is formed on the surface, such stones are of poor weathering quality.

2) **Attrition test:** Attrition test is used for checking the rate of wear of stones used in road construction. For conducting this test, take 5kg of stones of size about 60mm. Six pieces are put in both the cylinders of Deval's attrition testing machine. Diameter of the cylinder is 200mm and length 340mm. Axis of the cylinder makes an angle of 30° with the horizontal. Close the cylinder and rotate it for 5 hours at the rate of 30 revolutions per minute. After 5 hours of rotation the contents are taken out from the cylinders and they are passed through a sieve of 1.5mm size. The quantity of weight retained in the sieve is weighed.

$$\text{Percentage wear} = \frac{\text{Loss in weight}}{\text{Initial weight}} \times 100$$

For good quality stone percentage wear should be less than 3%.

3) **Crushing test:** Crushing test is used for testing the crushing strength of stone. For

this test the sample stone is cut into cubes of 40mm sides. Take three sample cubes and place them in water for 72 hours.

The load bearing surface of the specimen is covered with 5mm thick plywood. Compression testing machine is used for testing crushing strength of cubes. Axial load is applied on the cube at the rate of 137.2 kg/cm² per minute. Note the maximum load at which the sample crushes. Then,

$$\text{Crushing strength of specimen} = \frac{\text{Breaking load}}{\text{Area of cross-section of specimen}}$$

For good quality stone crushing strength should be greater than 1000kg/cm².

4) **Crystallisation test:** Crystallisation test is carried out for testing the weathering resistance of stones. For this test, at least four stone cubes of sides 40mm are taken. They are dried for 72 hours and weighed. Then immersed in 14% solution of sodium sulphate for two hours. They are dried at 100°C and weighed. The difference in weight is noted. This procedure of drying, weighing, immersing and reweighing is repeated at least five times. Each time, note the change in weight of sample and express it as a percentage of original weight.

5) **Freezing and thawing test:** In this test the stone specimen is kept immersed in water for 24 hours. Then it is placed in a freezing mixture at -12°C for 24 hours. It is then warmed at atmospheric temperature. These procedures are repeated several times and observe the behavior of stone. If the stone is of good quality there will not be any deviation in the properties of the stone.

6) **Hardness test:** Hardness test is used for testing the hardness of stone. For this test, prepare a cylindrical sample stone of diameter 25mm and height 25mm. It is weighed and placed in Dorry's testing machine and apply a pressure of 1.25 kg. The annular steel disc of the machine is then rotated at a speed of 28 revolutions per minute. After 1000 revolutions the specimen is taken out and weighed. Then,

$$\text{Coefficient of hardness of specimen} = 20 - \frac{\text{Loss in weight in gm}}{3}$$

For stones used in road work coefficient of hardness should be greater than 17. If coefficient of hardness is in between 14 and 17 it is said to be of medium hardness and can be used for R.C.C work. Hardness less than 14 is of poor quality.

- | | | |
|------------------|-------------------------|------------------------------|
| 3. Crushing test | 4. Crystallisation test | 5. Freezing and thawing test |
| 6. Hardness test | 7. Impact test | 8. Water absorption test |

1) **Acid test:** Acid test is used for testing the durability of stone. For conducting this test, take a sample stone weighing about 50gm to 100gm. Place this sample stone in a solution of hydrochloric acid of strength 1% and it is kept there for seven days. The solution is agitated at intervals. A good building stone should maintain its sharp edges and it should be free from any

powder formation at the end of the period. If edges are broken and powder formed on surface, such stones are of poor weathering quality.

2) **Attrition test:** Attrition test is used for checking the rate of wear of stones used in road construction. For conducting this test take 5kg of stones of size about 60mm. Six pieces are put in both the cylinders of Deval's attrition testing machine. Diameter of cylinder is 200mm and length 340mm. Axis of the cylinder makes an angle of 30° with horizontal. Close the cylinder and rotate it for 5 hours at the rate of 30 revolutions per minute. After 5 hours of rotation the contents are taken out from the cylinders and they are passed through a sieve of 1.5mm size. The quantity of weight retained in the sieve is weighed.

$$\text{Percentage wear} = \frac{\text{Loss in weight}}{\text{Initial weight}} \times 100$$

For good quality stone percentage wear should be less than 3%.

3) **Crushing test:** Crushing test is used for testing the crushing strength of stone. In this test the sample stone is cut in to cubes of 40mm sides. Take three sample cubes and place it in water for 72 hours.

The load bearing surface of the specimen is covered with 5mm thick plywood. Compression testing machine is used for testing crushing strength of cubes. Axial load applied on the cube at the rate of 137.2 kg/cm² per minute. Note the maximum load at which the sample crushes. Then,

$$\text{Crushing strength of specimen} = \frac{\text{Breaking Load}}{\text{Area of cross-section of specimen}}$$

For good quality stone crushing strength should be greater than 1000kg/cm².

4) **Crystallisation test:** Crystallisation test is carried out for testing the weathering resistance of stones. For this test, at least four stone cubes of sides 40mm are taken. They are dried for 72 hours and weighed. Then immersed in 14% solution of sodium sulphate for two hours. They are dried at 100°C and weighed. The difference in weight is noted. This procedure of drying, weighing, immersing and reweighing is repeated at least five times. Each time, note the change in weight of sample and expressed it as a percentage of original weight.

5) **Freezing and thawing test:** In this test the stone specimen is kept immersed in water for 24 hours. Then it is placed in a freezing mixture at -12°C for 24 hours. It is then warmed at atmospheric temperature. These procedures are repeated several times and observe the behavior of stone. If the stone is of good quality there will not be any deviation in the properties of the stone.

6) **Hardness test:** Hardness test is used for testing the hardness of stone. For this test prepare a cylindrical sample stone of diameter 25mm and height 25mm. It is weighed and

placed in Dorry's testing machine and apply a pressure of 1.25 kg. The annular steel disc of machine is then rotated at a speed of 28 revolutions per minute. After 1000 revolution the specimen is taken out and weighed. Then,

$$\text{Coefficient of hardness of specimen} = 20 - \frac{\text{Loss in weight in gm}}{3}$$

For stones used in road work coefficient of hardness should be greater than 17. If coefficient of hardness is in between 14 and 17 it is said to be of medium hardness and can be used for R.C.C work. Hardness less than 14 is of poor quality.

7) **Impact test:** Impact test is used for testing the toughness of stone. For conducting this test prepare a cylinder of diameter 25mm diameter and 25mm height from the sample stone. It is placed on cast iron anvil of impact testing machine. A steel hammer of weight '2kg' is allowed to fall axially in vertical direction over the specimen. Height of first blow is 1cm, second blow from 2cm height and 3rd blow from 3cm height and so on. The blow at which the specimen break is noted. If it is nth blow, toughness index of stone is 'n'.

Toughness index greater than 19 represent good quality stone 13-19 represent moderately tough stone. If it is less than 13 then it is of poor quality.

8) **Water absorption test:** Prepare a cube weighing about 50gm from the given sample stone. Note the actual weight of stone. It is then immersed in water for 24 hours. The cube is taken out of water and surface water wiped off and note the weight of the sample. Note the increase in weight of the sample.

$$\% \text{ absorption of water by weight after 24 hrs} = \frac{\text{Increase in weight of sample}}{\text{Original weight of sample}}$$

For good quality stone water absorption should not exceed 0.60.

3.3. BRICKS

Brick is one of the oldest building materials and it is extensively used even at present because of its durability, strength, reliability, low cost, easy availability, etc. Bricks are obtained by moulding clay in rectangular blocks of uniform size and then by drying and burning these blocks in brick kilns.

3.3.2 COMPOSITION OF GOOD BRICK EARTH :

A good brick earth should contain clay and sand in such a way that when water is added, it can be easily moulded and dried without cracking or warping.

Following are the constituents of good brick earth :

1. **Alumina :** A good brick earth should contain 20 to 30% of alumina. This constituent imparts plasticity to earth so that it can be moulded easily. If alumina is present in excess, raw bricks shrink and warp during drying and burning.

2. **Silica :** A good brick earth should contain 50 to 60% of silica. Presence of this constituent prevents cracking, shrinking and warping of raw bricks. It imparts uniform shape to the bricks. If silica is in excess, it makes the brick brittle.

3. **Lime** : A good brick earth should contain a small quantity of lime (<5%). Lime causes grains of sand to melt and bind the particles of clay together. It prevents shrinkage of bricks. If lime is excess, it will cause the brick to melt and hence its shape is lost.

4. **Oxide of iron** : A good brick earth should contain a small quantity of oxides of iron (about 5 to 6%). Iron oxide act as a flux to cause the grains of sand to melt and this helps bind the particles together. It imparts red colour to brick on burning. Excess amount of iron oxide makes the brick dark blue.

5. **Magnesia** : A good brick earth should contain a very small quantity of magnesia (<1%). Magnesia imparts yellow colour to brick and it decreases shrinkage. Excess magnesia leads to decay of bricks.

3.3.3. PROPERTIES OF GOOD BRICKS:

Good brick should have the following properties:

1. Bricks should have perfect edges, well burnt in kilns, copper coloured, free from cracks with sharp and square edges.
2. It should be uniform in shape and of standard size.
3. Colour should be uniform and bright.
4. The brick when broken should show a bright homogeneous and uniform compact structure free from voids.
5. It should produce clear ringing sound when struck with each other.
6. Water absorption should not be greater than 20% for first class bricks and 22% for second class bricks when soaked in water for 24 hours.
7. Brick should be sufficiently hard, i.e. no nail impression must be present when scratched.
8. It should not break when dropped from a height of one metre.
9. It should have low thermal conductivity and should be sound proof.
10. Good brick should not show any white or grey deposits of salts when immersed in water and dried, i.e. *efflorescence*.
11. Good brick should not have crushing strength below 5.5N/mm²

3.3.4. STANDARD SIZE AND WEIGHT OF BRICKS :

Size of standard brick is 19 x 9 x 9cm or this brick is known as modular bricks. The size of bricks including mortar thickness is known as nominal size i.e. 20 x 10 x 10cm. Average weight of brick is about 3 to 3.5kg.

3.3.5 SPECIAL TYPES OF BRICKS :

- 1) Face bricks
- 2) Fire bricks
- 3) Glazed or coloured bricks

- | | | |
|----------------------|-------------------|----------------------|
| 4) Imitation bricks. | 5) Channel bricks | 6) Coping bricks |
| 7) Hollow bricks | 8) Paving bricks | 9) Perforated bricks |

1) **Face bricks**: Special bricks having uniform colour, texture, size, etc are used for face works, sometimes it may contain some face design. It is used for garden walls, steps, side walls, and other exposed works where good appearance is desired.

2) **Fire bricks**: They are made up of special fire clay. And it is used for lining furnaces, fire-places, etc, where hightemperature are prevalent and where ordinary bricks get decomposed.

3) **Glazed and coloured bricks**: Glazed and coloured bricks have one surface glazed in colour. They are used for exterior surfaces of walls in hospitals, dairies, etc where cleanliness is important.

4) **Imitation bricks**: Bricks made up of Portland cement and sand are known as imitation bricks. They are used for the construction of compound wall, partition wall, etc. These bricks have same qualities as good mortar.

5) **Channel bricks**: These bricks are moulded to the shape of a gutter or a channel and they are glazed to prevent sediment deposition. These bricks are used to function as drains.

6) **Coping bricks**: These bricks are made to suit the thickness of walls on which coping is to be provided. It take various forms such as chamfered, half-round or saddle-back.

7) **Hollow bricks**: These brick are also known as cellular or cavity bricks. Such bricks have wall thickness of about 20 of 25mm. They are light in weight hence transportation cost is less. These bricks reduce the transmission of heat, sound and damp. They are used in the construction of brick partitioning.

8) **Paving bricks**: These bricks are prepared from clay containing a higher percentage of iron. Excess iron vitrifies the bricks at a low temperature; such bricks resist the abrasive action of traffic effectively. Thus they can be used for the construction of foot paths, garden walks, stable floor, etc.

9) **Perforated bricks**: These bricks contain cylindrical holes through out their thickness. These bricks are light in weight and they require less quantity of clay for their preparation. Bricks with perforation of about 30 to 40% of the total area of the corresponding face of the brick would offer adequate thermal insulation property. The distance between the side of brick and edge of perforation should not be less than 15mm. Water absorption should not exceed 20% by weight. The compressive strength of perforated bricks should not be less than 7N/mm². These bricks are used for brick wall where thermal insulation is

important. Figure 3.2 shows a perforated brick.

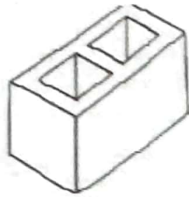

fig. 3.1 Hollow brick

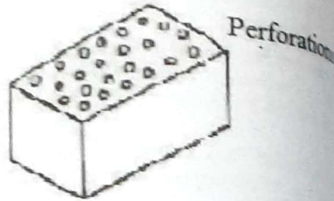

fig. 3.2 Perforated brick

3.3.6 TEST FOR BRICKS:

The following tests are conducted on bricks to decide its suitability for the construction

- i) Absorption test
- ii) Crushing strength test
- iii) Hardness test
- iv) Soundness test
- v) Presence of soluble salts
- vi) Shape and size
- vii) Structure
- viii) Warpage

(i) **Absorption test**: In this test, the dry weight of the brick is noted and immersed in water for 16 hrs. Then it is weighed again. The difference in weight indicates the quantity of water absorbed by the brick. The % water absorption should not exceed 20% of dry weight of brick for class upto 125 and 15% for class 150 and above

(ii) **Crushing strength**: Crushing strength of brick is tested in a compression testing machine. Brick is immersed in water for 24 hours. The brick is then taken out and excess water wiped off. It is then placed on the compression testing machine and load is applied axially at a uniform rate of 14N/mm²/minute till it breaks. Note the maximum load at which brick crushes.

$$\text{Crushing strength of brick} = \frac{\text{Maximum load}}{\text{Area of bearing face}}$$

The maximum load at which the brick crushes is noted. Minimum compressive strength of brick is 3.5N/mm², and for superior quality it is 7 to 14N/mm².

As per IS 1077, based on compressive strength bricks are classified as follows

Table 1. Different IS classification of brick

Class Designation	Average compressive strength not less than (N/mm ²)
350	35
300	30
250	25
200	20
175	17.5
150	15
125	12.5
100	10
75	7.5
50	5
35	3.5

(iii) **Hardness test**: A scratch is made on brick surface with the help of finger nail, if no nail impression left on the surface, the brick is treated to be sufficiently hard.

(iv) **Soundness test**: Two bricks are taken and they are struck with each other. Bricks of good quality should not break and will produce a clear ringing sound.

(v) **Presence of soluble salts**: Soluble salts if present in bricks will cause **efflorescence** on the surface of bricks. For finding out the presence of soluble salts, immerse the brick in water for 24 hours. It is then taken out and allowed to dry in shade. Presence of gray or white deposit on its surface indicates the presence of soluble salts.

Efflorescence is reported as nil when there is no precipitate on the surface of brick surface. If the white deposit cover about 10 % of surface, the efflorescence is said to be slight, and it is considered as moderate when the white deposits cover about 50 % of the surface area. If gray or white deposit were found on more than 50% of the surface, the efflorescence is heavy and that brick cannot be used for construction.

(vi) **Shape and size**: Bricks should be of standard size and its shape should be truly rectangular with sharp edges. For checking this 20 bricks of standard size 19 x 9 x 9 cm selected at

random and they are stacked length wise along the width and height. For good quality bricks (Class A) length of array is about 3680 to 3920mm, width of array 1740 to 1860mm and height of array 1740 to 1860 mm. For Class B ranges of length, width and height are respectively 3500-4100, 1650-1950 and 1650-1950mm.

(vii) **Structure:** In this test, a brick is broken and its structure is examined. It should be homogeneous, compact and free from any defects such as voids, lumps, etc.

(ix) **Warpage:** For measuring warpage of brick after removing dirt from the surface place the brick on a flat surface. using scale measure the greatest distance of brick from flat surface. This directly give the warpage of brick.

3.3.7 CLASSIFICATION OF BRICKS

Bricks can be classified into four major groups based on the method of manufacturing. Specification of different classes are as below.

1. First class bricks

- They are machine or table moulded and burnt in kilns.
- They have rectangular shape with sharp edges and uniform size.
- They are free from cracks, flaws or lumps.
- The crushing strength shall not be less than 10.5N/mm^2 .
- It should be well burnt and shall not be scratchable by finger nail.
- Water absorption should not be greater than 15%.
- Fractured surface should have uniform colour and texture

2. Second class bricks

- They are ground moulded and burnt in kilns.
- They have rectangular shape with sharp edges but slight irregularities in the shape.
- They shall be free from cracks but slight flaws and lumps are permitted.
- The crushing strength shall not be less than 7N/mm^2 .
- Water absorption should not be greater than 22%.

3. Third class bricks

- They are ground moulded and burnt in clamps.
- They may not have regular shape and size.
- They may be slightly over burnt or under burnt..
- These bricks produce dull sound when struck together.
- Water absorption should not be greater than 24%.

4. Fourth class bricks

- These are ground moulded and burnt in clamps.

- They are over burnt bricks with irregular shape and size..
- They are dark and brittle..
- These bricks are not used in normal construction works.

3.4 CEMENT

Cement is considered to be the most inevitable material for construction purposes. Cement is a material which possesses very good adhesive and cohesive properties making it good for bonding mineral fragments into a strong compact mass. Cement is obtained by burning and crushing of argillaceous and calcareous materials. On setting cement resembles a variety of sandstone found in Portland of England and is therefore known as Portland cement. Other types of cements are rapid hardening cement, acid-resistant cement, blast furnace cement, Quick setting cement, water-proof cement, white cement, puzzolana cement, coloured cement, etc.

3.4.1. COMPOSITION OF ORDINARY CEMENT:

Ordinary cement contains calcareous and argillaceous materials in proportion about 4:1. In calcareous material CaCO_3 is the major component and in argillaceous material, clay is the major component. For good quality cement the ingredients and their percentage should be within the following range.as in table 3.2

3.4.2. Functions of ingredients

- Lime:** Lime is one of the important constituent of cement. Excess lime makes the cement unsound and causes the cement to expand and disintegrate. But deficiency of lime decreases the strength of cement and it causes cement to set quickly.
- Silica:** Silica impart strength to cement with the formation of tri-calcium silica and di-calcium silicate, they are the major constituents which impart strength to cement. Excess silica increases the strength but it increase the setting time too.
- Alumina:** Alumina impart quick setting property to the cement. It acts as a flux and it lowers the clinkering temperature (temperature at which clinkers formed in kiln is about 1400°C to 1600°C). Excess alumina weakens the cement.
- Calcium Sulphate:** It is in the form of gypsum. It is used to increase the initial setting time of concrete.
- Iron oxide:** This ingredient imparts colour, hardness and strength to cement.
- Magnesia:** Magnesia imparts hardness and colour to cement but excess magnesia makes the cement unsound.
- Sulphur:** A very small amount of sulphur is useful in making sound cement. But

8. **Alkalies:** Excess alkalies causes efflorescence and staining when used in concrete work, brickwork or masonry mortar. The amount of alkali oxide (K₂O and Na₂O) in cement should not exceed 1%. Excess quantity of alkali oxide (greater than 1%) causes cracks in concrete or mortar when it hardens.

Ingredient	Percentage	Range in %
Lime (CaO)	62	62 - 67
Silica (SiO ₂)	22	17 - 25
Alumina (Al ₂ O ₃)	5	3 - 8
Calcium sulphate (CaSO ₄)	4	3 - 4
Iron Oxide (Fe ₂ O ₃)	3	3 - 4
Iron Oxide (Fe ₂ O ₃)	2	0 - 3
Magnesia (MgO)	1	1 - 3
Sulphur (S)	1	0 - 1
Alkalies		
Total	100%	

Table 3.2. Percentage of ingredients in cement

3.4.3. SETTING ACTION OF CEMENT:

When water is added to cement, the ingredients of cement react chemically with water and form various complicated compounds like Tricalcium aluminate, Tetra-calcium aluminoferrite, Tricalcium silicate and Di-calcium silicate. Formation of these compounds is simultaneous. The strength of cement paste goes on increasing with time i.e. it attains 70% of its final strength in 28 days and about 90% of its final strength in one year. The percentage of these chemical compounds in Portland cement is as follows:

- Tri-calcium aluminate (C₃A) - 4 to 14%
- Tri-calcium - formed within 24 hours
- Alumino-ferrite (C₄AF) - 10 to 18%
- Tri-calcium silicate (C₃S) - 45 to 65% } formed within a week
- Di-calcium silicate (C₂S) - 15 to 35% } formed very slowly

3.4.4. PROPERTIES OF CEMENT:

Properties of cement can be classified into two groups:

1. Physical properties and
2. Chemical properties

a. Physical properties:

a. Colour: Cement should be of uniform colour i.e. gray with light greenish shade. It should be free from lumps and should be cool when felt with hand. If we throw a small quantity of cement into a bucket of water it should sink into the bottom of bucket.

b. Fineness: It is a measure of mean size of grains in cement. It can be measured by sieve test. When sieved through 90 micron sieve, the quantity of residue left after sieving should not exceed 10%. Permeability test is also used for checking fineness of cement, for that specific surface area should not be less than 2250 cm²/gm.

c. Setting time: Setting of cement is the process of hardening of cement paste into hard solid mass. Initial setting time should not be less than 30 minutes and final setting time should not be more than 600 minutes for ordinary Portland cement. (refer testing of cement)

d. Soundness of cement: Cement paste after setting should not undergo large change in its volume, which may lead to disintegration and cracking. The cement which shows such a volume change is said to be unsound. Le-Chatelier apparatus is used to find the soundness, for ordinary portland cement the expansion measured with this apparatus should be less than 10mm.

b Chemical Properties

Chemical composition in cement should be as follows:

- a. Ratio of % of Alumina to Iron oxides should not be less than 0.66.
- b. Ratio of % of Lime to that of Alumina, Iron oxides and Silica should not be less than 0.66 and not be greater than 1.02.
- c. Total loss on ignition should not be greater than 5%.
- d. Sulphur content, calculated as SO₃ should not be greater than 2.5%
- e. Weight of insoluble residues in cement should not be greater than 4%.

3.4.5. GRADES OF CEMENT:

Grade is the 28 days strength when tested as per Indian Standards under standard conditions. If it is 33-grade cement then it has compressive strength equivalent to 33 MPa (33 N/mm²). Similarly 43 & 53 grades.

Ordinary Portland Cement (OPC) is classified into 3 grades, viz. 33, 43 & 53 grades denoted as C33, C43 and C53.

3.4.6. TEST FOR CEMENT

There are two modes of test (i) field test for determining roughly the quality of cement and (ii) laboratory test for deciding precisely the quality of cement.

i. Field-tests for cement

- (a) Colour test
- (b) Physical property of cement

- (c) Presence of lumps
 - (d) Strength
- a) **Colour test:** Colour of cement should be uniform. Typical cement colour is gray with a light greenish shade. Change of colour shows an indication of excess lime or clay and the degree of burning.
- b) **Physical Property of cement:** Cement should feel smooth when rubbed in between the fingers. Or if a small quantity of cement is thrown in a bucket of water, it should not flow and should not form lumps.
- c) **Presence of lumps:** The cement should be free from hard lumps. Such lumps are formed by the absorption of moisture from the atmosphere. Cement bags containing lumps should be avoided.
- d) **Strength:** There are two methods for determining the strength of cement.
- (i) Prepare a briquette of size 75 mm x 25 mm x 12 mm with cement and sand in proportion 1:6. It is immersed in water for 3 days. For good quality cement, it is difficult to break the briquette.
 - (ii) Prepare a block of cement 25 mm x 25 mm and 200mm long. It is immersed in water for 7 days then placed on supports 150mm apart and it is loaded with a weight of 34N at the centre of the beam. The blocks should not show any sign of failure means it is of good quality.

ii. Laboratory tests.

- (a) Fineness test
- (b) Compressive strength test
- (c) Tensile strength test
- (d) Consistency test
- (e) Setting times
- (f) Soundness test

(a) **Fineness test:** This test is used for checking the proper grinding of cement. For testing the fineness of cement take 100 gm of cement and it is continuously passed through standard sieve No.9 for 15 minutes. The residue is then weighed. According to IS 269-1976 this weight should not be more than 10% of its original weight.

(b) **Compressive strength test:** For checking the compressive strength of cement, prepare a mortar of cement and sand in proportion 1:3 with water cement ratio 0.4 (ie if 1 gm of cement is used take 3x gram sand and 0.4x gram water for preparing the mortar). Prepare six cubes of sides 76mm. After placing mortar in mould compact it with a vibrator for 2 minutes. After 24 hours remove the specimen from moulds and they are submerged in clean water for curing. The cubes are then tested in compressive strength testing machine at the end of 3rd days and 7th day. Three cubes are tested each time for finding out the compressive strength at the end of 3rd and 7th days. During the test the load is applied uniformly at the rate of 35N/mm².

No.	Grades of cement	Details
1	33 Grade (IS: 269 -1989)	1. The compressive strength after 28 days is 33 N/mm ² 2. Used for general construction works in normal environmental conditions. 3. Cannot be used where higher grade of concrete above M-20 is required. 4. The use of this cement has progressively and virtually phased out.
2	43 Grade Cement (IS: 8112 - 1989)	1. Most widely used cement for general construction work. 2. Minimum 28 days Compressive Strength -43 N/mm ² 3. Used for construction of residential, commercial and industrial buildings, roads, bridges, flyovers, irrigation projects and other general civil construction works. 4. Suitable for all of applications- RCC, Plastering, Masonry 5. Rajasree is the premium OPC43 brand in the market giving strength of around 65 MPa at 28days.
3.	53 Grade Cement (IS: 12269 - 1987)	1. Introduced in 1991 by Grasim - Birla Super. 2. Minimum 28 days Compressive strength - 53 N/mm ² 3. Gives 10-15% saving in cement consumption & 5-8% saving in steel consumption provided higher grades of concrete say M30 and above are used. 4. Useful for high rise buildings bridges, flyovers, chimneys and pre-stressed structures where high grade concrete is required. 5. 53S - special grade cement as per IS: 12269 -1987 used for the construction of sleepers.

Table 3.2. Different grades of cement:

The compressive strength at the end of three days should not be less than 11.5N/mm² and at the end of 7 days should not be less than 17.5N/mm² as per IS269-1989.

(c) **Tensile Strength:** For testing tensile strength prepare 1:3 mix cement mortar and placed in briquette moulds. A typical briquette is shown in figure 3.3. Compact the mortar till water appears on the surface. Prepare 12 standard briquettes. After 24 hours the

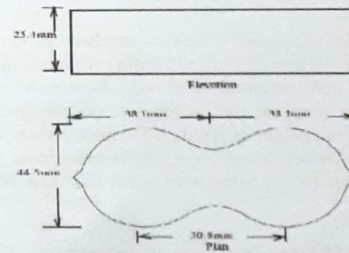

Fig 3.3

Briquettes are carefully removed from the mould and they are submerged in clean water for curing. The briquette is tested in tension testing machine at the end of 3rd and 7th days. Six briquettes are tested in each test.

Compressive strength of briquette should not be less than 2N/mm² at the end of 3rd days and 2.5N/mm² at the end of 7th days as per IS 269-1989.

(d) **Consistency test:** For testing consistency of cement, prepare cement paste by thoroughly mixing 300 gm cement and 90 gm water. Fill the mould of Vicat apparatus (refer figure 10.3.). The time interval between the addition of water to cement and the paste in mould is known as the time of gauging. Time of gauging should be in between to 4¼ minutes.

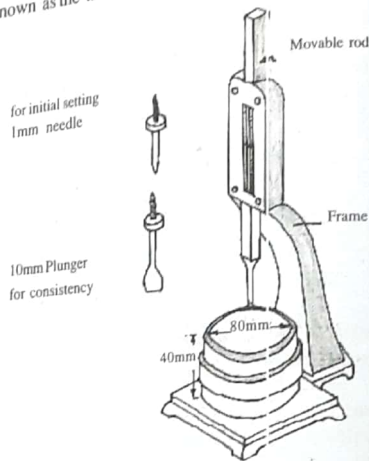

Fig. 3.4 Vicat Apparatus

Vicat apparatus consist of a frame which is attached to a movable rod weighing 300 gm and having diameter 10 mm and length 50mm. An indicator is attached to the movable rod for measuring the penetration of rod. For checking the consistency of cement attach plunger to the movable rod. And lower the plunger gently to the paste in the mould. The settlement of plunger is noted. If the penetration is between 5 mm from the bottom of mould, the water added is correct. If penetration is less than 5 mm repeat the experiment by preparing a paste with water less than 90gm till the required penetration is obtained.

According to IS 269-1989 the consistency of cement paste should be between 27% to 33%.

(c) **Setting times:** This test is used for detecting the deterioration of cement due to storage. This test is carried out to find out

(i) initial setting time and (ii) final setting time of cement.

(i) **Initial setting time:** For checking initial setting time of cement, take 300 gm of cement and it is mixed with percentage of water as determined from consistency test. This paste is filled in the vicat mould. The square needle connected to the movable rod is allowed to penetrate in to the paste. In the beginning the needle penetrates completely. This process of penetration checked for another place in the same paste at regular intervals till the needles does not penetrate completely. The needle should penetrate up to about 5 mm from the bottom of mould.

The initial setting time is the interval between the addition of water to cement and the stage when needle ceases to penetrate completely.

According to IS 269-1989 initial setting time of ordinary Portland cement should not be less than 30 minutes.

(ii) **Final Setting Time :** For checking final setting time prepare a cement paste and it is filled in the vicat mould. The needle with annular collar attached to the movable rod is released gently. The time at which the sharp end of the needle makes an impression on test block and collar fails to do so is noted.

The final setting time is the difference between the time at which water was added to cement and time at which the needle fails to makes an impression on test block.

According to IS 269-1989 final setting time of ordinary portland cement should not be less than 600 minutes(10 hours).

(f) **Soundness test:** Soundness is ability of cement to maintain a constant volume. Le Chatelier apparatus as shown in figure is used for testing consistency (soundness) of cement.

Prepare a cement paste with percentage of water as determined in the consistency test. The mould is placed on a glass plate and it is filled by cement paste, covered the mould with another glass plate. A small weight is placed at top and the whole assembly is submerged in water at 24 to 35°C for 24 hours. The distance between the points of indicator is noted. The mould is again placed in water and heat is applied in such a way that boiling point of water is reached in about 30 minutes and continue boiling of water for one hour. Then remove the mould from water and allowed to cool down. Measure the distance between indicator. The difference between the two measurements indicate the expansion of cement and it should not exceed 10mm for good quality cement. The change in distance is a measure of the unsoundness.

Briquettes are carefully removed from the mould and they are submerged in clean water for curing. The briquette is tested in tension testing machine at the end of 3rd and 7th days. Six briquettes are tested in each test.

Compressive strength of briquette should not be less than 2N/mm² at the end of 3rd days and 2.5N/mm² at the end of 7th days as per IS 269-1989.

(d) **Consistency test:** For testing consistency of cement, prepare cement paste by thoroughly mixing 300 gm cement and 90 gm water. Fill the mould of Vicat apparatus (refer figure 10.3.). The time interval between the addition of water to cement and the time when the paste in mould is known as the time of gauging. Time of gauging should be in between 4 to 4 1/4 minutes.

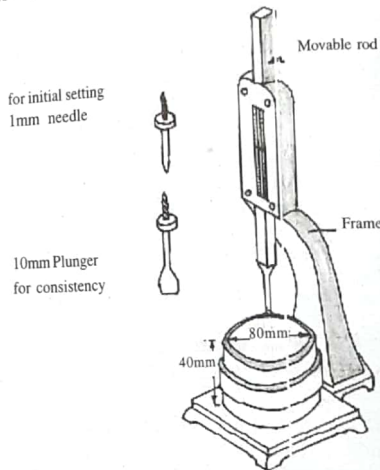

Fig. 3.4 Vicat Apparatus

Vicat apparatus consist of a frame which is attached to a movable rod weighing 300 gm and having diameter 10 mm and length 50mm. An indicator is attached to the movable rod for measuring the penetration of rod. For checking the consistency of cement attach plunger to the movable rod. And lower the plunger gently to the mould. The settlement of plunger is noted. If the penetration is between 5 to 25 mm from the bottom of mould, the water added is correct. If penetration is less than 5 mm or more than 25 mm, repeat the experiment by preparing a paste with water less than 90gm till the required penetration is obtained.

According to IS 269-1989 the consistency of cement paste should be between 25 to 33%..

(c) **Setting times:** This test is used for detecting the deterioration of cement due to storage. This test is carried out to find out

(i) initial setting time and (ii) final setting time of cement.

(i) **Initial setting time:** For checking initial setting time of cement, take 300 gm of cement and it is mixed with percentage of water as determined from consistency test. This paste is filled in the vicat mould. The square needle connected to the movable rod is allowed to penetrate in to the paste. In the beginning the needle penetrates completely. This process of penetration checked for another place in the same paste at regular intervals till the needles does not penetrate completely. The needle should penetrate up to about 5 mm from the bottom of mould.

The initial setting time is the interval between the addition of water to cement and the stage when needle ceases to penetrate completely.

According to IS 269-1989 initial setting time of ordinary Portland cement should not be less than 30 minutes.

(ii) **Final Setting Time :** For checking final setting time prepare a cement paste and it is filled in the vicat mould. The needle with annular collar attached to the movable rod is released gently. The time at which the sharp end of the needle makes an impression on test block and collar fails to do so is noted.

The final setting time is the difference between the time at which water was added to cement and time at which the needle fails to makes an impression on test block.

According to IS 269-1989 final setting time of ordinary portland cement should not be less than 600 minutes(10 hours).

(f) **Soundness test:** Soundness is ability of cement to maintain a constant volume. Le Chatelier apparatus as shown in figure is used for testing consistency (soundness) of cement.

Prepare a cement paste with percentage of water as determined in the consistency test. The mould is placed on a glass plate and it is filled by cement paste, covered the mould with another glass plate. A small weight is placed at top and the whole assembly is submerged in water at 24 to 35°C for 24 hours. The distance between the points of indicator is noted. The mould is again placed in water and heat is applied in such a way that boiling point of water is reached in about 30 minutes and continue boiling of water for one hour. Then remove the mould from water and allowed to cool down. Measure the distance between indicator. The difference between the two measurements indicate the expansion of cement and it should not exceed 10mm for good quality cement. The change in distance is a measure of the unsoundness.

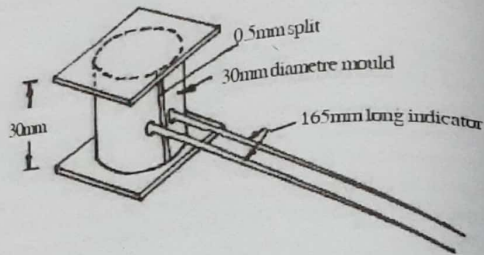

Fig 3.5 Le Chatelier Apparatus

3.4.7. ADVANTAGES OF CEMENT:

Following are the various advantages of cement:

- (a) It give strength to masonry.
- (b) It is an excellent binding material
- (c) Offer good resistance to moisture
- (d) It is easily workable
- (e) Hardens early
- (f) Possess good plasticity.

3.4.8. Uses of cement

Following are the various uses of cement:

1. For making concrete for laying roofs, floors and for constructing beams, columns, lintels, stairs, foundation etc.
2. For making mortar for brick masonry, stone masonry, pointing plastering, etc.
3. For the construction of important structures like dams, bridges, water tanks etc.
4. For the construction of roads, runway, wells, posts etc.
5. For the manufacture of pre-cast structures, pipes etc.

34.9. TYPES OF CEMENT

Following are the different types of cement:

1. Portland cement
2. Quick setting cement
3. Low heat cement
4. High alumina cement
5. Expanding cement
6. Rapid hardening cement
7. Sulphate resisting cement
8. White cement
9. Coloured cement
10. Waterproof cement

1. **Portland cement:** Ordinary portland cement is available in market in three different grades, i.e. C33, C43 and C53. (IS 269, IS 8112 and IS 12269) Here 33, 43, 53 represents cube strength.

of cement mortar (1:3 mix) cubes, of size 15cm, after 28 days in N/mm². For the construction of high strength structures C43 and 53 are preferred. For special purpose construction other types of cements are used.

2. **Quick setting cement:** It is produced by adding small percentage of aluminum sulphate and reduce the percentage of gypsum before grinding clinkers in tube mills and ball mills. The setting of cement starts within few minutes after addition of water and it becomes hard within 30 minutes. This type of cement is used for laying concrete under water.

3. **Low Heat Cement:** For this cement heat generated during setting is very small. It contains lower percentage of tri-calcium aluminate and higher percentage of di-calcium silicate. It is used for concreting of dam, abutment etc.

4. **High Alumina Cement:** It is produced by grinding clinkers formed by calcining bauxite and lime. For the high alumina cement, total alumina content should not be less than 32 percentage. Initial setting time of this cement is more than 3.5 hours and final setting time is about 5 hours. High alumina cement resists the action of frost and acids. It can withstand high temperature and attain maximum strength within a short period.

It is used for making refractory concrete, and for insulation of furnaces. It is highly corrosion resistant, acid resistant so used for facing construction related to such purposes.

5. **Expanding cement:** Expanding cement is produced by adding an expanding medium like sulpho-aluminate and a stabilizing agent to the ordinary cement. Hence this cement expand where as ordinary cement shrink during curing. This cement is used for repairing damaged concrete surfaces due to cracks. And for constructing water retaining structures.

6. **Rapid Hardening Cement:** It is produced by burning the ingredients of ordinary cement at high temperature and increasing the lime content and by fine grinding of clinkers. For this cement initial and final setting times are same as that of ordinary cement but they attains high strength within few days.

It is used for the work which is to be completed speedily and economically. It is light in weight and curing period is short. Compressive strength of this type of concrete after one day is 11.5N/mm² and after three days is 21N/mm². Tensile strength after one day and 3 days are 2N/mm² and 3N/mm² respectively.

7. **Sulphate resisting cement:** In sulphate resisting cement the percentage of tri-calcium aluminate is less than 5 percent and it results in the increase of resisting power against sulphate. Sulphate resisting cement is used for structures which may be damaged due to severe alkaline conditions like canal lining, culverts, syphons, etc.

8. **White cement:** White cement is prepared from raw materials which are free from colouring agents like oxides of iron, manganese or chromium. For burning of this cement oil fuel is used and it is more costly than ordinary cement. It is white in colour and it is used for floor finish, plaster work, ornamental work, for moulding sculptures and statues, for painting garden furniture, etc.

9. **Coloured cement:** The cement of desired colour may be obtained by intimately mixing mineral pigments with ordinary cement. The coloured cements are widely used for finished floors, external walls, stair treads, etc.

10. **Waterproof cement:** Waterproof substances like calcium stearate, aluminum stearate and gypsum treated with tannic acid are added to ordinary portland cement during grinding of clinkers. This can be used for plastering water retaining structures, roof, water proof concrete. Hydrophobic cement (prevent the entry of atmospheric moisture) and oil well cements (can be pumped for three hours under high pressure and temperature so it is used for oil well construction) are also available in market.

3.5 AGGREGATES

Aggregate is general term applied to those inert or chemically inactive materials which are bonded together by cement and water to form concrete. About 75% of volume of concrete is composed of aggregate so properties of concrete affects the properties of concrete like workability strength, durability and economy. Normal materials with uniform shear strength in all directions are ideal for use as aggregate. Most of the aggregate used are naturally occurring aggregates such as river sand, gravel, crushed rock etc. Artificially prepared aggregates are broken bricks, crushed air cooled blast furnace slag etc. Light weight aggregates are, expanded clinker, coke, saw dust, expanded slate etc. Aggregates may be classified in to two groups (a) fine aggregate and (b) coarse aggregate.

According to IS:383-1963, fine aggregate are aggregates which passes through 4.75mm IS sieve and coarse aggregates are aggregates which retained on 4.75mm IS sieve. (i.e. size of fine aggregate less than 4.75mm and coarse aggregate greater than 4.75mm)

3.5.1. Qualities of good aggregate:

- Aggregate should be hard, dense, durable and chemically inert.
- Aggregate should not contain harmful ingredients like lignite, mica, pyrites, dust, alkali, sea shells etc.
- It should be free from organic impurities.
- It should not contain any harmful material which may affect the strength of concrete and steel reinforcement.
- The shape and size of the aggregate boost the strength and workability of concrete.
- Toughness of aggregate used for concreting should not exceed 45%.
- Aggregate abrasion value should not exceed 16%.
- Specific gravity of good aggregate should be in between 2.6 to 2.7.
- For good quality aggregate water absorption should not be greater than 10%.

should be in between 10.8×10^{-6} to $16.2 \times 10^{-6} / ^\circ\text{C}$.

- Aggregate should have thermal expansion similar to that of cement matrix.
- Aggregate should be sound enough to resist excessive changes in volume due to change in physical conditions
- For good quality aggregate coefficient of thermal expansion should be low.

3.5.2. Fineness Modulus:

Fineness modulus of an aggregate is an index number which is roughly proportional to the average size of the particles in the aggregate and it is obtained by adding the total percentage by weight of the aggregates retained on each specified sieves (80mm, 40mm, 20mm, 10mm, 4.75mm, 2.36mm, 1.18mm, 600micron, 300micron, and 150micron IS sieves) and dividing it by 100 (IS 6471:1972).

3.5.3. Grading of aggregates:

Gradation or grain size distribution means the proportions of specified size of aggregates distributed in a mass of aggregate. The proportion of different sizes of particle should be in such a way that it is easier to pack particles of different sizes together and the smaller ones can occupy the voids between the larger particles. By using proper grading of aggregate we can reduce the quantity of cement. The process of mixing aggregates of various sizes to get the proper gradation is called *blending*.

For satisfactory workability of a mix it should contain sufficient quantity of material smaller than British Sieve No. 52. Size coarse aggregate should not be greater than $\frac{1}{4}$ th the thickness of member.

Factors, which govern the desired aggregate grading are:

- Relative volume occupied by the aggregate
- Surface area of the aggregate
- Workability of the mix
- Chances of segregation and bleeding
- Durability and shrinkage of concrete
- Economy is also an important factor

3.6. CONCRETE :

Concrete can be defined as an artificial building material obtained by mixing cement, fine aggregate, coarse aggregate and water in suitable proportion. Cement act as a binding material and it forms a paste with water and hold coarse and fine aggregates together to form a solid mass. The concrete mix is used for constructing slabs, roofs, retaining walls, pillars, dams, etc.

Concrete being a mixture of cement, aggregate and water, the properties of constituents affect the properties of concrete. Quantity of cement and water affect the strength of concrete. Size and shape of aggregate affect the strength and workability of concrete. Compaction (the

method of removing voids in between the aggregate) also influence the properties of concrete. There are two stages for concrete a) freshly prepared concrete (i.e. in plastic stage) (b) hardened concrete (after attaining in its full strength)

3.6.1. Properties of freshly prepared concrete:

Properties of freshly prepared concrete are

- (i) Workability
- (ii) Segregation and
- (iii) Bleeding.

(i) **Workability:** Workability is the ease with which concrete can be mixed, transported and placed in position. Good quality concrete should possess good mix ability, transportability, mouldability, and compact ability.

(ii) **Segregation:** Segregation can be defined as separating out of the constituents of a concrete mix during transportation of freshly prepared concrete.

(iii) **Bleeding:** Bleeding is defined as separation of water or mortar from the freshly prepared concrete. This is due to high water content in the mix. This will cause formation of a porous weak and non-durable concrete at the top of the placed concrete.

3.6.2. Properties of hardened concrete:

Properties of hardened concrete are as follows:

(i) **Strength:** Good quality concrete in hardened state should possess desired crushing strength. The compressive strength of concrete at 28 days after casting is known as **designed**

a) **Cement:** Cement is the most important ingredient of concrete. It is used to bind the fine and coarse aggregates together. Most of the concrete work is done with ordinary Portland cement. Other special varieties of cement like water proof cement; rapid hardening cement and high alumina cement are used under certain circumstances.

b) **Fine aggregate:** According to IS 383-1963 fine aggregates are inert or chemically inactive material which passes through 4.75mm IS Sieve. River sand, crushed stone, crushed gravel, etc are used as fine aggregate. Fine aggregates are used to make the concrete denser by filling the voids of coarse aggregates. It is used to make the concrete mix economical and it reduce the shrinkage of concrete on hardening.

c) **Coarse aggregate:** These are inert materials which retained in 4.75mm IS sieve. Uncrushed gravel, broken bricks, crushed stone, etc., are used as coarse aggregate. Coarse aggregate is used to make the concrete strong and tough.

Mix ratio	Strength	Nature of work
1 : 1 : 2	M ₂₅ (Very high strength)	Heavily loaded columns and beams
1 : 1½ : 3	M ₂₀ (Higher strength)	Water retaining structures, piles, pre-cast structures etc.
1 : 2 : 4	M ₁₅ (High-strength)	For all general R.C.C. works in building such as beam, column, slab, lintel, staircase, etc
1 : 3 : 6	M ₁₀ (Medium strength)	For culverts, retaining walls, etc
1 : 4 : 8	Low strength	Mass concrete work for heavy walls, foundations,
1 : 5 : 10	Low strength	Mass concrete work for heavy walls, foundations,

Table 3.3. Proportioning of concrete and their strength and uses

3.6.3. Ingredients of Concrete:

The following are the ingredients of concrete

- a) Cement
- b) Fine aggregate
- c) Coarse aggregate
- d) Water

d) **Water:** Water used for mixing concrete should be potable (fit to drink). Water serves the following functions. (i) it acts chemically with cement to form a paste for binding the aggregates. (ii) it enables the concrete to flow in to moulds. Water required for hydration of one part of cement is about 0.3 part of water, but for lubricating the aggregate extra water is required. So water cement ratio for the medium and high strength concrete is 0.6 and 0.35 respectively.

Abraham's water-cement ratio law states that for any given conditions of test the strength of a workable concrete mix is dependant only on water -cement ratio. The amount of water added during concrete mixing affects the workability and strength. Insufficient quantity of water makes a concrete mix harsh and unworkable where as an excess quantity of water causes bleeding and segregation of concrete.

Water cement ratio is the ratio of weight of water to the weight of cement in a mix. The strength of concrete is inversely proportional to the water cement ratio. ie decrease the water cement ratio we can increase the strength of concrete. But for water cement ratio less than 3.5 it is very difficult work with that concrete.

Water cement ratio depends upon the following factors:

- (i) Quality of cement
- (ii) Quality of aggregate
- (iii) Internal moisture content
- (iv) Atmospheric temperature
- (v) Size and age of test specimen

Sometimes ingredients other than the above are added in concrete for improving or imparting certain properties and these ingredients are known as **admixtures**. Addition of admixtures improve durability, workability, water-resisting power, strength of concrete,

setting and hardening of concrete, reduce shrinkage, impart colour, reduce bleeding etc. Commonly used admixtures are lime, alum, barium oxide, soap, aluminium sulphate, calcium chloride, mineral and organic oils, bitumen, etc.

3.6.4. Proportioning of materials

The process of selection of relative proportion of fine aggregate, coarse aggregate, cement and water for obtaining a concrete of required quality is known as proportioning of concrete. Proper proportioning is essential for the production of a serviceable and durable concrete at an economical cost. One common practice of expressing the proportions of materials in the form of parts or ratios of cement, sand and coarse aggregate, with cement considered as unity.

For example, 1:2:4 mix contains one part cement two part fine aggregate and four part coarse aggregate by volume. Water content is expressed separately in terms of water-cement ratio.

3.6.5. Batching of concrete

The process of measuring the quantity of cement, fine aggregate, coarse aggregate and water for concreting is called batching. It will ensure the uniformity of proportions and aggregate grading.

Advantages of concrete batching are:

- i) The desired *strength* of concrete can be prepared if the ingredients are measured correctly before the mixing.
- ii) The *workability* of concrete can be improved.
- iii) Properly batched concrete produce highly *durable* concrete.
- iv) Proper batching increase the *economy* of the mix.

3.6.6. Mixing of concrete

The process of rolling, folding and spreading of various constituents of concrete is known as mixing of concrete. Concrete should be thoroughly mixed to ensure that cement and water paste completely covers the surface of aggregate and there is uniform distribution of materials in the concrete mass.

There are two types of concrete mixing:

- i) Hand mixing
- ii) Machine mixing

i) **Hand mixing:** Manual mixing of various ingredients of concrete is called hand mixing. It is employed for mixing concrete for small works. For hand mixing, the dry ingredients (fine aggregate, coarse aggregate) and cement are measured separately and stacked on a water tight platform.

Step 1: Spread the required quantity of fine aggregate on the platform and then spread the required quantity of cement uniformly over the sand layer.

Step 2: With the help of shovels, mix sand and cement in dry state till the a mixture of uniform colour is obtained.

Step 3: Spread the sand-cement mixture uniformly on the platform and then spread the required quantity of the coarse aggregate and mix the mixture in dry state thoroughly.

Step 4 : On obtaining a uniform coloured mix with sand cement and coarse aggregate make a depression in the centre of the mixed materials.

Step 5 : Add 80% of the required quantity of water in the depression and turn the mix towards the middle with the help of shovel. Mixture is mixed thoroughly till a uniform colour and consistency is obtained.

Step 6 : Add the remaining water and continue mixing till a uniform colour and consistency is obtained.

This prepared mix should be used within 30 minutes after adding water. For important works (ie for M30, M35, M40 etc) with hand mixing, it is advisable to use 10% more cement than specified quantity.

ii) Machine mixing:

The process of mixing various constituents of concrete by machine is called machine mixing. In this method all materials including water are collected in a revolving drum and then rotate the drum for a certain period.

There are two types of mixers :

- (a) hand operated concrete mixer and
- (b) Tilting drum type concrete mixer.

(a) **Hand operated concrete mixer or non-tilting type mixer:** This mixer consists of a drum mounted on two wheels, which can be steered in any direction by a turning handle. The drum rotates on a fixed shaft with taper roller bearing to provide smooth operation. Capacity of drum varies from 0.2m³ to 2m³. In most cases the drum rotates in one direction and 15 to 20 revolution of drum ensures a complete mixing. The direction of rotation may be reversed to discharge the concrete.

(b) **Tilting drum mixer:** This mixer consists of a drum of capacity varying from 0.1 to 3.0m³. Blades are fixed inside the drum for mixing the concrete in quickest time. It is able to produce 60m³ of concrete in one hour.

The concrete mixer should be thoroughly washed and cleaned after use, otherwise it is difficult to remove cakes of concrete later and it reduce the efficiency of mixer. Here also

concrete discharged from the mixer should be consumed within 30 minutes after preparation. Compared to hand mixing machine mixing gives better quality concrete at a faster rate (ie. 1 to 2 minutes).

3.6.8 Curing of concrete

Curing may be defined as the operation of keeping freshly prepared concrete moist or wet for a specified period after its finishing. This is just for ensuring the complete hydration of cement particles or other cementing materials for attaining its full strength. To achieve proper curing the following requirements should be full filled:

- a. Maintenance of proper water content in the concrete which is essential for the hydration of cement.
- b. Maintenance of proper temperature in the whole mass of concrete.
- c. Protecting a freshly prepared concrete from damage.

Purpose of curing:

By curing, durability and impermeability of concrete increases and shrinkage is reduced. It improves resistance of concrete to abrasion. Increase in strength of concrete with age is very rapid for properly cured concrete.

3.6.9. Different methods of curing:

1. Ponding with water
2. Covering concrete with wet jute.
3. Covering concrete with wet sand, saw dust etc.
4. Covering concrete with polythene sheet or plastic sheet.
5. Intermittent spraying of water and continuous sprinkling of water

Period of curing depends up on the type of cement and nature of work. Curing period for different cement concrete is as follows:

For ordinary Portland cement period of curing is about 7 to 14 days.

For rapid hardening cement period of curing is just 4 days.

3.6.10. Advantages of cement concrete

Advantages of cement concrete are:

- a. Concrete can be readily moulded into durable structural elements of different shape and sizes.
- b. It has high compressive strength.
- c. It hardens with age and the process of hardening continues for a long time even after concrete attains sufficient strength.
- d. Concrete is free from corrosion and not affected by weathering.
- e. Concrete forms a hard surface for resisting abrasion.
- f. Concrete provides good bond with reinforcement, brick, stone etc.
- g. Concrete possess sufficient plasticity.

- h. It is possible to mechanise the preparation and placing of concrete.
- i. Concrete is more economical than steel as 90% of its volume is made from natural materials.
- j. Quality of concrete depends on quality of cement, aggregate, water, curing of concrete and the workmanship.
- k. Concrete on setting act as an impervious body.

3.6.11 Disadvantages of concrete

- a. Tensile strength of plain concrete is very low.
- b. Self weight of concrete structure is high.
- c. Concrete is not suitable for speedy construction. It requires sufficient time for attaining its strength.
- d. Low resistance to cracking.
- e. Concrete possess low ductility and low resistance to cracking.
- e. Reuse of the structure made with concrete is not possible in normal case, but in case of precast structures it can be reused after proper handling.

3.7. PRE-CAST CONCRETE:

Pre-cast concrete is a factory made product, moulded in desired size and shape. Pre-cast products are now available in various forms like pipes, fencing posts, paving blocks, piles, doors and window frames, hollow blocks, etc. Pre-cast members offers high standard of finishing.

Preparation of pre-cast products

Following are the steps involved in the construction of pre-cast structures:

- (i) Prepare a mould to the shape of product in timber or steel.
- (ii) Reinforcement is put up in the mould as per design specification.
- (iii) The concrete is mixed in desired proportion and placed in the mould. Concrete is vibrated to avoid void space inside.
- (iv) Smoothen the surface to get a good finish.
- (v) The products are then cured in special tanks for predefined period.
- (vi) The pre-cast structure is then shipped to the site.

Advantages of pre-cast concrete:

- (i) Concrete of superior quality is produced as it is possible to have high technical control on the production of concrete.
- (ii) Pre-cast units are prepared in steel mould by trained labour, thus they may have desired shape and size.
- (iii) Pre-cast structures can be dismantled, when required and they can be suitably reused.
- (iv) The construction work can be completed in a short time.
- (v) It is really cheap compared to cast-in-situ concrete (concrete prepared at the site) due to elimination of scaffolding, formwork and the surface plastering is reduced.

to one coat.

Disadvantages:

- (i) If not properly handled, it may get damaged during transportation.
- (ii) It is difficult to produce satisfactory connection between the pre-cast members.
- (iii) It is necessary to arrange special equipment for lifting and moving of pre-cast units.

3.8. PRE-STRESSED CONCRETE:

Pre-stressed concrete is defined as concrete in which there have been introduced internal stresses of such magnitude and direction, that stresses resulting from given external loading are counteracted to certain desired degree or "Reinforced concrete members in which reinforcement provided with initial compressive stress is known as pre-stressed concrete".

In ordinary reinforced concrete construction, we can not economically make use of higher strength of concrete, as the steel needed for such type of work will be excessive. Whereas in the case of pre-stressed concrete we can use a higher strength of concrete and there by economise in the section.

In reinforced concrete structures, due to tensile stress and bending stress cracks may develop on concrete surface. To prevent the development of cracks, it is necessary to reduce the tensile stresses in reinforced concrete members. For reducing these stresses, the tension zone of the member should be provided with an initial compression or pre-stress. There are two methods for pre-stressing

(i) Pre-tensioned method and (ii) Post-tensioned method.

3.8.1. Pre tensioned concrete: In this method reinforcements are placed in designed position and tension is applied by anchoring to an anchoring post. The formwork is re-erected around the tensioned reinforcement. Concrete is then poured in to the formwork and compacted and cured. As soon as the concrete has fully hardened and developed the desired strength, the connection between the reinforcement and anchor posts are cut off. Due to bond between steel and concrete, the tensioned steel transfer the induced force due to shortening to the concrete. This compresses the hardened concrete member and it is pre-stressed. This method of pre-stressing is used for beams, fence posts, simply supported slabs, etc.

3.8.2. Post-tensioned method: In this method pre-stressing force is applied to the steel after the concrete has completely set and has attained the desired strength. The reinforcing steel is in the form of single wire or cables made up of separate wires. The wires are stretched through holes left for them in the pre-cast concrete member. The pre-stressing force is created by tensioning the cables by means of hydraulic jack. The anchorage at the ends of cables are adjusted to keep the stretched cable in position. Now, cement grout is forced under pressure to fill the space around the cable completely. Finally anchorage at two ends are covered with a protective coat of grout.

Advantages of pre-stressed concrete:

1. It provides a construction which is always free from cracks.
2. Reduce the quantity of steel and concrete.
3. It saves material as well as head load of member.
4. Smaller sections are used in this type of construction. Thus very large spans can be built in pre-stressed concrete.
5. The cost of shuttering and centering in large structures are reduced when pre-cast pre-stressed elements are assembled.
6. Large area can be covered without the use of interior columns.
7. Fire resistant and corrosion resistant compared to steel works.
8. Long life since there is no crack.
9. It is used for constructing structures like docks, wharfs and jetties exposed to sea water; exposed structure at gas work; bridges exposed to pollution; structural works in dairies exposed to lactic acid are common examples of concrete exposed to corrosion.

Disadvantages of pre-stressed concrete:

1. Extra labour cost connected with the stressing of the tendons.
2. More costly for small structures.

3.9. REINFORCED CONCRETE:

Plain cement concrete (PCC) is a hard mixture of cement, fine aggregate, coarse aggregate and water. It is very strong in compression but at the same time it is very weak in tension. Due to this property of concrete it cannot be used for structures which has to carry tensile load. If we reinforce this plain cement concrete with steel bars this combined structure can resist tension and compression. This combination of plain concrete and steel is known as "Reinforced Cement Concrete (RCC)".

3.9.1. Properties of Reinforced concrete are:

- i. Due to very good bond existing between steel and concrete excess stress acting in concrete can be transmitted in to steel.
- ii. Cement grout protect the reinforcement from corrosion
- iii. There is no chemical reaction between steel and concrete.
- iv. Since coefficient of linear expansion of concrete and steel are nearly same, no internal stress develop due to variation of temperature.

3.12.2. Advantages of RCC over Plain Cement Concrete(PCC):

- i. It is more rigid than PCC structure.
- ii. It is durable and fire resisting.
- iii. It is not attacked by white ants, fungus, termites and vermin
- iv. Less maintenance cost.
- v. Impermeable to moisture so it can be used for the construction of water retaining structure.
- vi. Economical due to its long life.
- vii. It can be mould into any shape.

3.10. STEEL

Steel is an alloy of Iron and Carbon with traces of other elements. Total carbon content in steel varies from 0.25 to 1.5%. The smaller the quantity of carbon its property is similar to wrought iron (carbon content less than 1.15%) and as the carbon content increases its characteristics is similar to cast iron (carbon 1.5 to 4%).

Types of steel :

- Carbon up to 0.25 % - mild steel or soft steel
- Carbon 0.25 to 0.75 % - medium carbon steel
- Carbon 0.75 to 1.25 % - high carbon steel, tool steel, hard steel,
- Carbon > 1.25% - extra hard steel

3.10.1. Uses of steel :

- a) Soft and malleable steel is used for rolling into thin sheets.
- b) Very soft and ductile steel used for drawing into wires.
- c) Very hard and brittle steel is used for making tools.
- d) Steels are highly elastic, ductile, malleable, forgeable and weldable. They can be hardened and tempered and are fusible at a lower temperature than wrought iron. They retain magnetic properties as iron. Smithing of steel is more difficult than wrought iron. Steel is strong in compression and tension hence it is suitable for all construction works
- e) Cast iron is granular and can take up only compressive stress and hence its use is limited to compression members. Wrought iron is fibrous in nature and it is suitable to resist tensile stresses.

Table 3.4. Different types of steel and there purpose

Name of Steel	Purpose
Mild Steel	For making motor body, sheet metal, Boiler Plates, tin plates, structural steel etc.
Medium carbon steel	For making rails, tyres, hammers, springs, stamping dies etc.
High carbon steel	For making chisels , hammers, saw, smithy tools, stone mason's tool, Axes, drills, punches etc.
Stainless steel	For making architectural panels, curtain walls, etc.

Manufacture of Steel: There are different processes for the manufacture of steel. Most widely used processes are Bessemer process, Cementation process, Electric process, Open-hearth process and Duplex process.

3.10.2. Market Forms of Steel

Steel is used to a large extent in modern multi-storied buildings. For buildings which are more than ten stories in height, construction using steel is economical. Due to ease in erection and heavy loads which structural steel work can take, it is commonly adopted for factory buildings. Following are the various forms in which rolled steel sections are available in market.

- (1) Angle Section
- (2) Channel Section
- (3) T-Section
- (4) I-Section
- (5) Flat bars
- (6) Square bars
- (7) Round bars
- (8) Expanded metals
- (9) Plates
- (10) Corrugated sheets
- (11) Pipes, tubes and sheets
- (12) Ribbed tor steel

(1) **Angle Sections:** Angles sections have two legs as shown in figure. If two legs are of equal length then they are known as equal angle section and otherwise unequal angle section. Equal angle sections are available in sizes varying from 20mm x 20mm x 3mm to 200mm x 200mm x 25mm and their corresponding weights are 9N/m and 736 N/m. Unequal angle section are available in sizes varying from 30mm x 20mm x 3mm to 200mm x 150mm x 18mm. The corresponding weights are 11N/m and 469 N/m.

Angle sections are used in the construction of steel roof trusses, filler Joist floors, steel columns, steel beams, cleats and as stiffeners in huge girders.

(2) **Channel Section:** Channel section consist of a web and two equal flanges as shown in fig. Typically a channel section is designated by the height of web and the width of flange. Channel sections are available from 100mm x 45 mm to 400 mm x 100mm with weight as 58 N/m and 494 N/m respectively.

Channel sections are widely used as structural members of the steel framed structures. They are used in the construction of built-in columns, crane girders, beams and steel bridges

(3) **T-Section:** T-section consists of a web and flange as shown in figures. It is designated by

its overall width and depth. T-sections are available from 20mm x 20mm x 8mm to 150mm x 150mm x 10mm with weight as 9N/m and 228N/m respectively. T-sections are widely used as members of steel roof trusses and to form built-up sections, chimney, steel bridges, etc.

(4) **I-sections** : I-sections are commonly known as rolled steel joists (R.S.J) or beams. An I-section consists of two flanges and a connecting web as shown in fig. It is designated by its overall depth, width of flange and weight per meter length. They are available in various sizes from 75mm x 50mm at 61N/m to 600mm x 210mm at 995N/m. I-sections are suitable for beams, columns are available in 'H' sections which vary in sizes from 150mm x 150mm at 271N/m to 450mm x 450mm at 925N/m.

R.S.J. are economical in material and are suitable for beams, lintels, columns, grillage foundation, etc. Unequal I-sections with heavy weight are used as rails.

(5) **Flat bars**: These are available in suitable widths varying from 3 to 40mm. They are widely used for the construction of steel grill works, windows and gates.

(6) **Square bars**: These are bars with square cross-section. Size of square bars varies from 5mm square to 25 mm square and their corresponding weight per metre length are 2.4 and 49N. They are widely used in the construction of steel grill works, windows, gates, etc.

(7) **Round bars**: These are bars with circular cross-section. They are available in diameters varying from 5 to 25mm and their corresponding weights per metre length of bars are 1.57 and 38N. They are widely used as reinforcement in concrete structures, construction of steel grill works, etc.

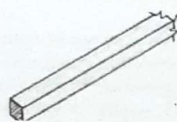

fig.3.6 Square bar



fig.3.7 Round bar

(8) **Expanded metals**: Expanded metals are formed by cutting and expanding either plate sheets or ribbed sheets of steel. A diamond mesh appearance is formed through out the area as shown in figure. The manufactured sheets are thus known as diamond mesh or expanded metal. Diamond mesh has sizes from 30 to 150mm across the shorter length of the mesh and is available in length 1 to 3m and width 5m.

Expanded metal is used as a reinforcement in ferro cement construction and for reinforcing foundation, road floors, bridges, etc. It is also used as a lathing material.

(9) **Plates**: Plate sections of steel are available in different sizes with thickness varying from 5 to 50mm and their corresponding weights are 392 N/mm² and 3925 N/mm². Plates are used

to connect steel beams for extension of length and for carrying tensional force in steel roof trusses. They are used to form built-up sections of steel.

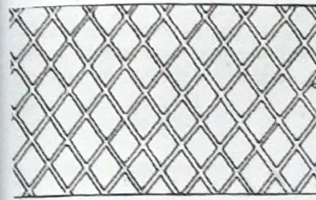

fig.3.8 Expanded metal

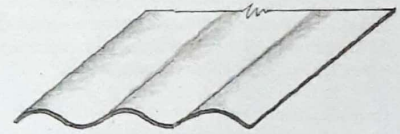

fig.3.9 Corrugated sheet

(10) **Corrugated sheets**: These are formed by passing steel sheets through grooves. These grooves bend and press sheets, and corrugations are formed on the sheets. These corrugated sheets are galvanized and they are known as galvanized iron sheets or GI. sheets. These sheets are widely used as roof covering material.

(11) **Pipes, tubes and steel sheets**: Pipes are used for light columns and other structural purposes as well as its primary use as liquid conduits. Tubes of different shapes are available in market like round, square and rectangular it is used for framing roof truss and for light structural works, scaffolding, etc. Pipes over 15cm is sometimes casted as corrugated pipes, due to the difficulty of threading of pipe.

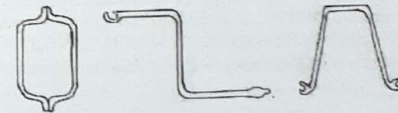

fig.3.10 Sheet pile and box pile

Table 3.5 . Difference between pipe and tube

Sl.no	Pipe	Tube
1	Pipe is designed to be threaded for connecting each other.	It is not threaded, and tubes are connected by welding.
2	Pipe designated by its inner diameter.	Tubes designated by its outer Diameter.

Steel sheets of thickness less than 1mm are used for sheet metal works. Thicker sheets are used for other miscellaneous works i.e. for building works, pile works like Box piles and sheet piles.

(12) **Mild steel (Corrosion Resistant Steel- CRS)**: Mild steel is corrosion resistant so they can increase the life of structure made up of it. Chemical composition of mild steel is 0.1% of carbon 0.65% phosphorous and sulphur 0.06%. Its yield strength is 250N/mm² and it is called Fe250. IS 432 is for mild steel.

Properties of mild steel:

1. It can be magnetised permanently
2. It can be readily forged and welded.
3. fibrous structure for mild steel
4. It is malleable and ductile.
5. It is not easily affected by salt water.
6. It is more tougher and more elastic than wrought iron.
7. Since it is strong in tension and compression it is used for all types of structural work.
8. It rust easily and rapidly.
9. Melting point is about 1400°C
10. Specific gravity 7.8

It is used for the construction of light and heavy engineering structures like ship, building, railway, automobile and electrical industries. Two forms of reinforcements are available in market Fe415 and Fe500 of different diameters (8, 10, 12, 16, 20, 22, 25, 28, 32, 36 and 40mm).

(13) **Tor steel**: The most commonly used steel bar for concrete reinforcement is TOR steel. The other names of TOR steel are CTD bar, deformed steel bar, twisted steel bar, HYSD bar and CWD bar. The TOR steel bars of grades TOR40, TOR50, TOR55 and Tor60 are available. It can be used for general concrete reinforcement in buildings, roads, bridges, sea wall, walls, dam, culverts etc

3.10.3. HYSD steel conforming to IS 1139&1786: HYSD steel (High Yield Strength Deformed steel) is having a yield strength of 415MPa, permissible tensile stress of 230MPa and proof stress of 0.2% are used as reinforcement in RCC works.

These bars are also known as Fe 415 HYSD bars. The ribbed or steel rods have ribs or projections on their surface and are produced by controlled cold twisting of hot-rolled bars. Each bar is to be twisted individually and it is tested to confirm the standard requirements. Due to the presence of ribs on the surface the following properties are improved, (i) yield stress (ii) tensile strength (iii) bond strength with concrete (that is about 40% more than plain bars).

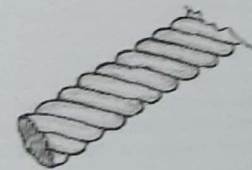

fig. 3.11 Ribbed tor steel bar

Chemical composition of mild steel is 0.3% of carbon 0.0555% phosphorous and sulphur 0.065%. Tor steel of four grades are available in market they are TOR40, TOR50, TOR55 and TOR60.

The ribbed-tor steel bars are available in sizes varying from 6 to 50mm diameter, with the corresponding weights per metre length as 2.22N and 154.10N. These bars are widely used as reinforcement in concrete structures such as buildings, bridges, docks, roads, pile foundations, pre-cast concrete works, irrigation works, etc.

1. Advantages of HYSD steel bars:

1. It is possible to bend these bars through 180 without the formation of any cracks.
2. It has 65% greater yield strength.
3. It has 80% greater bond strength.
4. It has satisfactory and easy weldability.
5. It provides 20% more factor of safety due to hyper resistance.
6. It is suitable for tension as well as compression.
7. It doesn't need end hooks thus reducing labour cost.
8. Net economy is achieved in cost up to 40% in tension side and 30% in compression side.

Table 3.6. Economy of mild and tor steel

Item	Required mild steel	Required Tor steel	% saving by wt.
Tension	100%	60%	40%
Compression	100%	70%	30%
Shear resistance	100%	75%	25%
Reinforcement	100%	80%	20%

MODERN CONSTRUCTION MATERIALS:

3.11. Architectural Glass

Architectural glass is glass that is used as a building material used for giving better appearance. It is most typically used as transparent glazing material in the building envelope including windows in the external walls. Glass also used for internal partitions and as an architectural feature. As seen in old churches, monuments and palaces.

The glass used for this purpose is typically whiter in colour than the clear glasses used for other applications. This glass can be laminated or toughened depending on the depth of the pattern to produce a safety glass.

Laminated glass is manufactured by bonding two or more layers of glass together with an interlayer, such as PVB, under heat and pressure, to create a single sheet of glass. When broken, the interlayer keeps the layers of glass bonded and prevents it from breaking apart. The interlayer can also give the glass a higher sound insulation rating. There are several types of laminated glasses manufactured using different types of glass and interlayers which produce different results when broken.

3.11.1 Glass

Glass is an inorganic material, which is rigid at room temperature. It is used in building construction for glazing doors and windows, for insulation and decoration. It is made by fusing mixture of oxides of silicon, boron or phosphorus with one of the basic oxides i.e. soda, potash, lime and magnesia and a quantity of waste glass at 1000°C or more and then cooling the mixture rapidly to prevent crystallisation. Mechanical strength of ordinary glass varies from 350 to 700kg/cm².

Properties of glass:

1. It absorbs, refract and transmits light.
2. It can take up high polish.
3. It is an excellent electrical insulator.
4. It is available in different colours.
5. It is extremely brittle.
6. It has no sharp melting point.
7. It is not affected by air or water.
8. It is not easily attacked by ordinary chemical agents.
9. It is transparent and translucent.
10. It has no definite crystalline structure.

Glasses available in market area :

1. **Sheet glass:** It is made by blowing glass in to hollow cylinder splitting the cylinder and then flattening it over a plane surface. It is extensively used in engineering works. Sheet glass is available in thickness 2,2.5,3,4,5,5.5 and 6.5 mm and sizes up to 175cm x 110cm.

2. **Plate glass:** It is made by pouring white-hot glass over an iron table and rolling it to form a uniform thickness under a heavy roller. Thickness of plate vary from 3 to 32mm and size up to 275cm x 90cm. It is stronger and transparent than sheet glass. It is used extensively for large paned glass doors and windows in shop fronts. It is used for making mirrors.

3. **Ground glass:** It is made either by grinding one side or by melting powdered glass up on it. It becomes translucent and transmits light without transparency. It is used for glazing doors and windows of toilets, bedrooms, and where privacy is required.

4. **Laminated glass:** It is made by binding two or more glasses plates with intervening layers of transparent plastics by applying excessive heat and pressure. It is suitable for automobile front glass, and also for doors and windows of buildings. It is available in thickness 4 to 20mm.

5. **Flint glass:** It is made from a mixture of silica and lead. It shines and takes up good polish. It is used as optical glass, for making electric bulbs and valves etc.

6. **Insulating glass:** It is made by hermetically sealing two layers of glass separated by 6mm to 12mm of dehydrated air to provide heat insulation and also to ensure transmission of light. It is used for glazed doors and windows.

7. **Bulletproof glass:** It is made of several layers of plate glass and alternate layers consist of vinyl resin plastic. The outer layers are of lesser thickness than inner layer. The thickness of this glass varies from 15 to 75mm. It is used for providing security and safety even against bullet that fails to pierce through it.

8. **Fiberglass:** It is made by minute glass rods. It is soft to touch, it does not absorb water and it is fire proof. It is not affected by vermin, water and acids. It is woven just like silk or wool. It is used for thermal insulation sheets, fiber glass reinforced plastics, etc.

9. **Optical glass:** Glass made by a special process to make it free from strains and defects. It is used for making lenses and prisms.

10. **Optical fiber glass :** Optical fibers are very fine strands of glass which have a core of pure glass, surrounded by different kinds of glass called cladding. Cladding possesses the property to reflect light, and the reflected light strikes back to the centre of the fiber. Thus the light rays are able to travel through the optical fiber by repeated reflection by the cladding. Optical fiber glasses are used in endoscope, an instrument used by doctors to view the interior of patient's body. It is also used in telecommunication for transmitting telephone calls, thus it replace metal wires.

11. **Coloured glass** : It is made by adding oxides of metal to molten glass so that the finished product is obtained of desired colour. Coloured glass is used in architectural works.

12. **Block glass**: Block glass is made hollow. Hollow blocks are sealed by fastening together two halves of pressed glass. The block glass is used for insulation against heat, cold and sound.

13. **Thermolux** : It is a compound glass consisting of thin mat or a layer of glass fiber between two sheets of ordinary glass which may be sheet, plate or other varieties. It forms a perfect diffusing medium both for day light or artificial lighting. And it provides very good thermal insulation, eliminate heat and glare.

14. **Wired glass**: It is made by embedding a wire mesh (0.45 to 0.56mm diameter) between the layers of the glass during its manufacturing process. It is a rough cast translucent glass and resist fire better than ordinary glass. It is used for fire-resisting doors and windows and also for roofs.

15. **Photo chromic glass**: This type of glass is obtained by adding silver iodide, so that glass becomes sensitive to light. As it darkens when exposed to bright sun light and return to its light shade in dim light, it is called photo chromic glass. It is very useful as sun shield, sunglasses, etc.

3.12. PLASTICS

Plastics are organic substances which consists of natural or synthetic resins with or without moulding compounds. Synthetic resins may be phenol, formaldehyde, cellulose vinyl, alkyd, etc. The moulding compounds are catalysts, fillers, hardeners, lubricants, pigments, plasticizer, solvent, etc.

Classification of plastics:

According to the heating effect plastics are classified as (i) Thermoplastics (ii) thermosetting plastic

(i) **Thermoplastics**: These plastic become soft when heated and hard when cooled. The process of softening and hardening may be repeated for an indefinite time. The main advantage of this type of plastic is that the scarp obtained from old and worn-out articles can be effectively used again.

Commonly used thermoplastic resins are :

- a) Vinyl
- b) Styrene
- c) Cellulose
- d) Acrylic

e) Alkyd

a) **Vinyl**: This resin is odourless, non-toxic, transparent and colourless. This is produced by passing acetylene gas through acetic acid or dry hydrogen chloride. Plastic prepared from this resins are odourless, non-toxic, transparent and colourless. It is coloured it is used for preparing cable and wire coatings.

b) **Styrene**: This resin is light in weight and possesses very high electric resistance. This resin is produced from ethylene, which is made from petroleum. Plastic prepared from this resins are widely used as insulators at radio frequency in wireless and television industry.

a) **Cellulose**: These resins are tough and strong. They are produced from various cellulose compounds such as cellulose acetate, cellulose esters, etc. Plastics prepared from cellulose are transparent and they possess excellent electrical properties.

b) **Acrylic**: This resin possesses excellent optical properties and it act as good insulator. It is derived from coal, petroleum and water by complicated processes. Plastic formed from this resins are used for safety glass, coloured and artificial jewels, lighting fittings, bath and sink units etc.

c) **Alkyd**: This resin possesses good electrical properties. It is made from glycerin and phthalic anhydride. It is used for preparing thin films of plastic.

(i) **Thermo-setting plastics**: These plastics become rigid when moulded at suitable pressure and temperature. Chemical change occurs during moulding, they set permanently and further application of heat does not alter their form.

Commonly used thermo-setting resins are:

- a) Phenol formaldehyde
- b) Phenol furfuraldehyde
- c) Urea formaldehyde
- d) casein

a) **Phenol formaldehyde** : Phenol is carbolic acid. It is prepared from coal tar or from benzene. Formaldehyde is a hydrocarbon. It is prepared synthetically from methane. Phenol formaldehyde is highly resistant to heat and it has excellent mechanical and electrical properties. Plastic prepared from this resins are used for paints, varnishes, electrical fittings, etc.

b) **Phenol furfuraldehyde** : Furfuraldehyde vapours are formed by digesting husks of rice, shells of ground-nuts, etc. with sulphuric acid in the presence of catalysts. These vapours when reacted with phenol, forms this resin. It is dark in colour and resist very high temperature.

c) **Urea formaldehyde:** Urea is prepared by heating a mixture of liquid carbon dioxide and liquid ammonia under pressure, when urea reacted with formaldehyde this resin is formed. It possesses excellent electrical properties. Plastic prepared from this resins are used for making adhesives for wood and wood products, lighting fixtures such as lamps, reflectors etc.

d) **Casein:** It is a phosphor protein and it is derived by the precipitation of milk with acids. It is easily workable and it possesses bright attractive appearance. Plastics, prepared from this resins are used for buckles, buttons etc.

Polyvinyl chloride (PVC) is most popularly accepted plastics for making pipes in buildings. Rigid PVC pipes are made by modifying the properties of PVC resins. PVC door and window are popular now.

Advantages of plastics

1. They are waterproof, rust proof, rot proof and termite proof.
2. They are cheap.
3. They have good electrical and optical property.
4. They are available in various colours.
5. They are clean, light and shining.
6. Just like wood it is possible to drill, punch and saw.
7. They can be used as thermal insulator.
8. Painting and polishing is not necessary.

3.13. CERAMIC

Ceramics can be defined as inorganic, nonmetallic materials. They are typically crystalline in nature and are compounds formed between metallic and nonmetallic elements such as aluminum and oxygen (alumina- Al_2O_3), calcium and oxygen (calcia - CaO), and silicon and nitrogen (silicon nitride- Si_3N_4). Ceramics form an important part of materials group. Ceramics are compounds between metallic and nonmetallic elements for which the inter-atomic bonds are either ionic or predominantly ionic.

The term ceramics comes from the Greek word *keramikos* which means 'burnt stuff'. Characteristic properties of ceramics are, in fact, optimized through thermal treatments. They exhibit physical properties those are different from that of metallic materials. Thus metallic materials, ceramics, and even polymers tend to complement each other in service.

Types and applications of ceramics

Ceramics greatly differ in their basic composition. The properties of ceramic materials also vary greatly due to differences in bonding, and thus found a wide range of engineering applications. Classification of ceramics based on their specific applications and composition are two most important ways among many. Based on their composition, ceramics are classified as: Oxides,

Carbides, Nitrides, Sulfides, Fluorides, etc. The other important classification of ceramics is based on their application, such as: Glasses, Clay products, Refractories, Abrasives, Ceramics, Advanced ceramics.

In general, ceramic materials used for engineering applications can be divided into two groups: traditional ceramics, and the engineering ceramics. Typically, traditional ceramics are made from three basic components: clay, silica (flint) and feldspar. For example bricks, tile, porcelain articles. However, engineering ceramics consist of highly pure compounds of aluminum oxide (Al_2O_3), silicon carbide (SiC) and silicon nitride (Si_3N_4). Glasses: glasses are a family group of ceramics – containers, windows, mirrors, lenses, etc. They are non-crystalline silicates containing other oxides, usually CaO , Na_2O , K_2O and Al_2O_3 which influence the glass properties and its color. Typical property of glasses that is important in engineering applications is its response to heating.

Diamond, silicon carbide, tungsten carbide, silica sand, aluminium oxide / corundum are some typical examples of abrasive ceramic materials.

Cements: cement, plaster of paris and lime come under this group of ceramics. The characteristic property of these materials is that when they are mixed with water, they form slurry which subsequently and hardens finally. Thus it is possible to form virtually any shape. They are used as bonding phase, for example between construction bricks.

Advanced ceramics: these are newly developed and manufactured in limited range for special applications. Usually their electrical, magnetic and optical properties and combination properties are exploited. Typical applications: heat engines, ceramic armor, electronic packaging, etc. Some typical ceramics and respective applications are as follows: Aluminium oxide / Alumina (Al_2O_3): it is one of most commonly used ceramic material. It is used in many applications such as to contain molten metal, where material is operated at very high temperatures under heavy loads, as insulators in spark plugs, and in some unique applications such as dental and medical use.

Aluminium nitride (AlN): because of its typical properties such as good electrical insulator but high thermal conductivity, it is used in many electronic applications such as in electronic circuits operating at a high frequency. It is also suitable for integrated circuits. Other electronic ceramics include – barium titanate ($BaTiO_3$) and Cordierite ($2MgO \cdot 2Al_2O_3 \cdot 5SiO_2$). Diamond is the hardest material known to available in nature.

3.14. Sound absorbing materials

Most of the common building materials absorb sound to a small extent. For absorbing sound some other materials to be incorporated on the surface of wall, roof, floor etc. Such materials are known as sound absorbing materials.

c) **Urea formaldehyde:** Urea is prepared by heating a mixture of liquid carbon dioxide and liquid ammonia under pressure, when urea reacted with formaldehyde this resin is formed. It possesses excellent electrical properties. Plastic prepared from this resins are used for making adhesives for wood and wood products, lighting fixtures such as lamps, reflectors etc.

d) **Casein :** It is a phosphor protein and it is derived by the precipitation of milk with acids. It is easily workable and it possesses bright attractive appearance. Plastics, prepared from these resins are used for buckles, buttons etc.

Polyvinyl chloride (PVC) is most popularly accepted plastics for making pipes in buildings. Rigid PVC pipes are made by modifying the properties of PVC resins. PVC door and window are popular now.

Advantages of plastics

1. They are waterproof, rust proof, rot proof and termite proof.
2. They are cheap.
3. They have good electrical and optical property.
4. They are available in various colours.
5. They are clean, light and shining.
6. Just like wood it is possible to drill, punch and saw.
7. They can be used as thermal insulator.
8. Painting and polishing is not necessary.

3.13. CERAMIC

Ceramics can be defined as inorganic, nonmetallic materials. They are typically crystalline in nature and are compounds formed between metallic and nonmetallic elements such as aluminium and oxygen (alumina- Al_2O_3), calcium and oxygen (calcia - CaO), and silicon and nitrogen (silicon nitride- Si_3N_4). Ceramics form an important part of materials group. Ceramics are compounds between metallic and nonmetallic elements for which the inter-atomic bonds are either ionic or predominantly ionic.

The term ceramics comes from the Greek word keramikos which means 'burnt stuff'. Characteristic properties of ceramics are, in fact, optimized through thermal treatments. They exhibit physical properties those are different from that of metallic materials. Thus metallic materials, ceramics, and even polymers tend to complement each other in service.

Types and applications of ceramics

Ceramics greatly differ in their basic composition. The properties of ceramic materials also vary greatly due to differences in bonding, and thus found a wide range of engineering applications. Classification of ceramics based on their specific applications and composition are two most important ways among many. Based on their composition, ceramics are classified as: Oxides

Carbides, Nitrides, Sulfides, Fluorides, etc. The other important classification of ceramics is based on their application, such as: Glasses, Clay products, Refractories, Abrasives, Cements, Advanced ceramics.

In general, ceramic materials used for engineering applications can be divided into two groups: traditional ceramics, and the engineering ceramics. Typically, traditional ceramics are made from three basic components: clay, silica (flint) and feldspar. For example bricks, tiles and porcelain articles. However, engineering ceramics consist of highly pure compounds of aluminium oxide (Al_2O_3), silicon carbide (SiC) and silicon nitride (Si_3N_4). Glasses: glasses are a familiar group of ceramics – containers, windows, mirrors, lenses, etc. They are non-crystalline silicates containing other oxides, usually CaO , Na_2O , K_2O and Al_2O_3 which influence the glass properties and its color. Typical property of glasses that is important in engineering applications is its response to heating.

Diamond, silicon carbide, tungsten carbide, silica sand, aluminium oxide / corundum are some typical examples of abrasive ceramic materials.

Cements: cement, plaster of paris and lime come under this group of ceramics. The characteristic property of these materials is that when they are mixed with water, they form slurry which sets subsequently and hardens finally. Thus it is possible to form virtually any shape. They are also used as bonding phase, for example between construction bricks.

Advanced ceramics: these are newly developed and manufactured in limited range for specific applications. Usually their electrical, magnetic and optical properties and combination of properties are exploited. Typical applications: heat engines, ceramic armors, electronic packaging, etc. Some typical ceramics and respective applications are as follows: Aluminium oxide / Alumina (Al_2O_3): it is one of most commonly used ceramic material. It is used in many applications such as to contain molten metal, where material is operated at very high temperatures under heavy loads, as insulators in spark plugs, and in some unique applications such as dental and medical use.

Aluminium nitride (AlN): because of its typical properties such as good electrical insulation but high thermal conductivity, it is used in many electronic applications such as in electrical circuits operating at a high frequency. It is also suitable for integrated circuits. Other electronic ceramics include – barium titanate ($BaTiO_3$) and Cordierite ($2MgO \cdot 2Al_2O_3 \cdot 5SiO_2$). Diamond it is the hardest material known to available in nature.

3.14. Sound absorbing materials

Most of the common building materials absorbs sound to a small extent. For absorbing sound some other materials to be incorporated on the surface of wall, roof, floor etc. Such materials are known as sound absorbing materials.

Qualities of good sound absorbing materials:

- (i) It should be economical in construction and maintenance.
- (ii) It should be waterproof, fire proof and sufficiently strong.
- (iii) It is good in appearance.

On striking the solid materials of room the sound waves experience greater resistance than in air. If sound wave strikes a resilient and porous surface, considerable energy will be dissipated as heat and passing through its pores which are inter connected through a series of small channels, the resultant absorption is relatively very high. An open window does not interface with the free passage of sound and it is considered as 100% absorbent, the absorbing capacity of other materials is compared with this open window unit as standard.

3.14.1. Classification of sound absorbing materials:

Sound absorption materials may be classified in to four groups

The first group includes soft materials like hair felt which are very good absorbers as they have large pores with inter-connected channels. They are now replaced by rock wool, asbestos, etc. The average value of coefficient of absorption of 25mm thick hair felt is 0.60.

Semi-hard materials in the form of porous fiberboards that are stiff serve as sound absorbent material as well as building panels. For 12mm thick fiberboard coefficient of absorption is 0.30.

Porous tiles of masonry and other products, which are installed on the walls, comes under third group. Acoustical tiles can fix easily, but it is costly. This type of materials is suitable for rooms having small area. Curtains comes under third group with coefficient of absorption 0.50.

Acoustical plasters come under fourth group. Acoustical plaster is also known as fibrous plaster and it includes granulated insulation material mixed with cement. For thickness of 20mm plaster and density 0.10gm/cm³ absorbent coefficient is 0.30.

Quilts and mats: These are prepared from mineral and glass wool and they are fixed in the form of acoustic blankets. For glass or mineral wool absorption coefficient is 0.9.

The main properties of a good sound absorbing material is its sound absorbing efficiency, low initial cost, fixing and maintenance cost; high durability, good appearance, fire and vermin proof qualities, low weight and capacity to reflect to light.

For broadcasting room special arrangements are required for keeping reverberation within the limits. Provide carpets on floor, curtains over certain walls and use different absorbing materials in different fashion on the walls and ceiling for absorbing sounds of lower frequencies. For library building just carpet covering for floor is enough because here walls are covered with book shelves which would act as an absorptive surface.

Table No.3.7. Sound absorbing material and their coefficient of absorption:

Sl. no	Material	Coefficient of sound absorption
1	Wood wool board of 25mm thickness	0.02
2	Glass sheet of 6mm thickness	0.01
3	Acoustical plaster of 20mm thickness	0.30
4	Quilts and mat	0.90
5	Hair felt of 25mm thickness	0.60
6	Porous fiber of 12mm thickness	0.30
7	Porous tiles	0.50

3.15. Thermal insulation and insulating material

A difference of temperature between the inside and outside or between different parts of a building will result in a transfer of heat from the warmer to the cooler area. Some building materials allow heat to pass rapidly while others do not allow passage of heat. The main aim of insulation is to minimize the transfer of heat between outside and inside of building.

3.15.1. General principles of thermal insulation:

- (i) The thermal resistance of an insulating material is directly proportional to its thickness.
- (ii) Provision of air gap and insulating agent is very important.
- (iii) The thermal resistance of a building depends on its orientation.

The building should be located in such a way that there is maximum transfer of solar energy in winter and minimum transfer of solar energy in summer.

3.15.2. Types of insulating materials:

There are mainly seven modes in which these materials are fabricated (i) loose fills (ii) blanket insulation (iii) bats (iv) insulating boards (v) slab or block insulation (vi) reflective shee materials and (vii) light weight aggregates.

(i) **Loose fill insulation:** It consists of fibrous materials like rock wool, slab wool, glass wool, cellulose or wood fiber wool. They also consists of granular loose materials of mineral or vegetable nature. Mineral wool is a fibrous material made of rock, slag and glass. These materials are conveyed to a large melting pot and the rock is melted under a high temperature. As it leaves the furnace, it is acted upon by a blast of steam which carries the beads of wool to an annealing chamber.

(ii) **Blanket insulation:** They are flexible fibrous materials supplied in rolls. They are made from mineral wool, processed wood fiber, cotton and animal hair. Their thickness varies from 5 to 8cm.

(iii) **Bat insulating material:** They are similar to blanket insulation but smaller in size and greater in thickness (5 to 9cm). They are available in smaller sizes suitable for framing units.

(iv) **Structural insulating board:** It is made by reducing wood cane or other materials to a pulp and then reassembling fibers in to boards. Adhesives are added to keep the fibers in position.

(v) **Slab insulations:** They are small rigid units of about 2.5cm in thickness and they are available in sizes up to 60 x 120 cm or more. It consists of cork board slabs, mineral wood slabs, vermiculite slabs, cellular glass slabs and cellular rubber slab bound together with cement.

(vi) **Reflective insulation:** This insulation depends entirely on their surface characteristics for their heat resistant property. Bright metallic surfaces are effective insulation material. Aluminum foils, surfaced gypsum boards, steel sheet reflective insulations or reflective coating applied on paper or other surfaces are various types of insulations commonly adopted.

(vii) **Light weight aggregates:** Cement and concrete products have lower heat resistance, but with the use of light weight aggregates such as blast furnace slag, burnt clay aggregate, vermiculite etc., the insulating resistance of concrete increased.

3.15.3. Thermal insulation of doors and windows:

1. Insulating glass or double glass with air gap may be provided for glazed doors and windows.
2. In order to reduce incidence of solar heat, protections in the form of sun breakers, weather sheds, projections, curtains may be provided on the exposed doors and windows

3.15.4. Thermal insulation of roofs:

1. Suitable shade may be provided on the roof surface.
2. Shining and reflecting materials may be forced on the top of exposed roof.
3. For flat roofs an air space may be created by arranging asbestos cement sheets.
4. Flat roofs may be kept cool by spraying or storing water at regular intervals.

3.15.5. Thermal insulation of exposed walls:

1. Suitable thickness of wall may be provided.
2. Hollow brick wall or cavity wall may be constructed
3. For partition an air space may be created by fixing hard board or batten.
4. The exposed wall may be constructed of thermal insulating materials.

3.15.6. Advantages of thermal insulation:

(a) **Comfort:** Due to thermal insulation the room remains cool in summer and warm in winter. Hence a room provided with thermal insulation gives comfort both in summer and winter.

(b) **Fuel saving:** Due to thermal insulation transfer of heat from inside to outside of the room is reduced. So less quantity of fuel is required to maintain the desired temperature in the room.

(c) **Condensation:** The provision of thermal insulating materials inside a room prevents condensation on interior walls and ceilings. Condensation is the deposition of moisture and it take place when warm air comes in contact with surfaces having temperature below the dew point.

3.16. Cement Blocks

Cement blocks are now used in building construction because of its light weight (compared to concrete block and stone), easy availability and due its economy compared to bricks, stones and massive concrete blocks. Cement blocks are very light due to the presence of cavity inside it. Air pockets inside the block gives thermal and sound insulation to the room for a certain extend.

Sizes - Originally only one or two types of blocks were available, but now a variety of blocks are manufactured. Standard size of block used in wall construction are:

- 39cm x 19cm x 30cm.
- 39cm x 19cm x 20cm and
- 39cm x 19cm x 10cm

3.16.1. Properties of Cement blocks :

- a. Appearance - This concrete blocks are light-gray incolour and have rough texture and is suitable for most types of plastering
- b. Sound insulation and acoustic control - Air voids present inside the cement blocks offer good sound and thermal insulation
- c. Fire resistance - Cement blocks are classified as non-combustible. 20cm thick blocks provide fire resistance of 3 hrs and 3hr load bearing capacity.

- d. Durability - Cement blocks do not rot or decay and are resistant to freeze-thaw cycles. They have good resistance to sulphate attack.
- e. Workability - Cement blocks are not so easy to handle as in case of brick due to its large size. By placing a single block it will cover about four times the area covered by brick.
- f. Compressive strength - Compressive strength is 3.0 N/mm^2 .
- g. Thermal conductivity - Thermal conductivity is 0.11 W/mK .
- h. Cement blocks can be recycled.
- i. These blocks are manufactured by mixing 60% fine aggregate and 6 to 12mm size coarse aggregate about 40%.

3.17. TIMBER

Timber is defined as the wood which is suitable for building or carpentry or other engineering purposes and it is applied to the trees having circumference of the trunk greater than 600 mm.

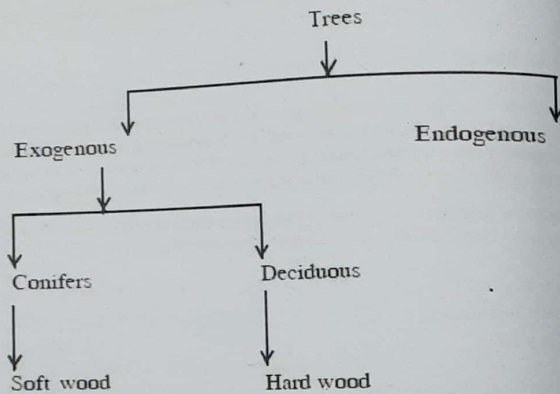

Classification of trees:

According to the mode of growth trees are classified as exogenous and endogenous.

a) **Exogenous trees:** Circumference of these trees increase in bulk by growing outwards. distinct consecutive rings known as annular rings are formed in the horizontal section of a tree.

Examples of exogenous trees are Teak, Sal, Pine, Oak etc. The exogenous trees are further subdivided in to (i) Conifers and (ii) Deciduous.

new ones are grown. These trees bear cone-shaped fruits, thus they are known as conifers. These trees yield soft woods which are generally light coloured, resinous, light in weight and weak. Hence they can not be used for building construction.

The deciduous trees are also known as the broad leaf trees and leaves of these trees fall in autumn and new ones appear in spring season. These trees yield hard wood which are usually close-grained, strong, heavy, dark colour, durable and non-resinous.

Table 3.8. Comparison of 'Soft wood' and 'Hard wood'

No	Item	Softwood	Hardwood
1.	Annual rings	Distinct	Indistinct
2.	Color	Light	Dark
3.	Fire resistance	Poor	More
4.	Medullary rays	Indistinct	Distinct
5.	Strength	Strong for pull and weak for resisting shear.	Equally strong for resisting tension, compression and shear.
6.	Structure	Resinous and split easily	Non - resinous and closed grain.
7.	Weight	Light	Heavy

Examples of soft woods are Deodar, Fir, Chir, Kail pine, Spruce etc. and those of hard wood are Mahogany, Oak, Teak, Babul, Sal etc.

b) **Endogenous trees:** These trees grow inwards and fibrous mass is seen in their longitudinal section. Examples of endogenous trees are Bamboo, Cane, Palm etc.

Structure of wood: Figure shows the transverse section of the trunk of an exogenous tree.

Pith: The central portion or core of the tree is called pith or medulla.

Heart wood: The inner annual ring surrounding the pith constitute the heart wood. This part imparts rigidity to the tree and provides strong and durable timber.

Sap wood: The outer annular rings between heart wood and cambium layer is known as the sap wood. It is light in weight and colour compared to heart wood.

Cambium Layer: The thin layer of sap between sap wood and inner bark is known as cambium layer

Inner bark and Outer bark: The inner skin or layer covering the cambium layer is known as the inner bark and it protects the cambium layer. The outer skin or cover of the tree is known as the outer bark.

Medullary rays: The thin radial fibers extending from pith to cambium layer are known as the medullary rays. The purpose of these rays is to hold together the annual rings of heart and sap wood.

Defects in Timber

The defects occurring in the timber are:

- (i) Defects due to conversion
- (ii) Defects due to fungi
- (iii) Defects due to insects
- (iv) Defects due to natural forces
- (v) Defects due to seasoning

3.17.1 QUALITIES OF GOOD TIMBER

Following are the qualities of good timber:

1. A freshly cut surface of timber should exhibit hard and of shining appearance.
2. Good timber is dark in colour. Light colour usually indicates weak timber.
3. A good timber should be free from defects such as shakes, knots etc.
4. A good timber should be durable. It should be capable of resisting the action of insects, chemicals, physical and mechanical agencies.
5. A good timber should have straight fibres and be elastic.
6. A good timber should retain its shape during seasoning or conversion. It should not warp or split.
7. A good timber should resist mechanical wear and tear in a better way.
8. A good timber should allow easy sawing, planing and working.
9. A good timber should be tough and strong enough and it should have uniform structure.
10. A good timber should resist weathering effects in a better way.
11. A good timber should possess enough strength in longitudinal and transverse direction.
12. Timber should have sweet smell and give a clear ringing sound when struck with each other.

3.17.2 PRESERVATION OF TIMBER

To improve the life of the timber and to protect the timber structures from the attack of fungi, insects etc. preservatives are applied on the surface of timber.

Usually applied preservatives are:

- i) ASCU – which is composition of hydrated arsenic pentoxide, copper sulphate and potassium dichromate.

- ii) Chemical salts such as copper sulphate, mercury chlorides, sodium fluoride and zinc chloride.
- iii) Coal tar
- iv) Creosote oil
- v) Oil paints
- vi) Solignum paints

3.18. SEASONING OF TIMBER

A newly cut tree contains about 50% of its own dry weight as water in the forms of sap and moisture. This moisture may lead to fermentation and consequent decay of timber. Hence this water is to be removed before timber can be used for any engineering purpose. This process of removing moisture or drying of timber is known as seasoning of timber.

3.18.1 Objectives of seasoning

1. To allow timber to burn easily.
2. To decrease the weight of timber and hence to lower the cost of transport and handling.
3. To improve hardness, stiffness and strength.
4. To make the timber safe from the attack of fungi and insects.
5. To reduce the tendency of timber to crack, shrink and warp etc.
6. To make timber fit for receiving treatment of paints, varnishes, preservatives etc.

3.18.2 Methods of seasoning

There are two methods of seasoning namely:

- a) Natural seasoning
- b) Artificial seasoning

a) **Natural seasoning:** In this method, seasoning of timber is carried out by natural air, hence it is also known as air seasoning. Following procedure is followed in natural seasoning.

Timber is cut and sawn into suitable sections of planks or scantling. The timber pieces can either be stacked horizontally or vertically, the former arrangement being very common. The platform of stock is made 30 cm higher than the ground level. The timber pieces are stored out according to length and thickness and are arranged in layers as in figure. Each layer is separated by good quality dry wood. This arrangement is protected from strong blow of wind, rain and extreme heat or sun. Air gets circulated between the layers and in course of time, the timber gets seasoned. This process takes a long time, even up to two years.

b) Artificial seasoning: Following are the various methods of artificial seasoning:

- i) Boiling
- ii) Chemical seasoning
- iii) Electrical seasoning
- iv) Kiln seasoning
- v) Water seasoning

i) **Boiling:** In this method timber is immersed in water and water is then boiled. Boiling water extended for 3 to 4 hours. Boiled timber is then dried very slowly under a shed. The period of seasoning and shrinkage are reduced by this method, but it affects the elasticity and strength of wood, this method of seasoning is quick but costly.

ii) **Chemical seasoning or salt seasoning:** In this method timber is immersed in a solution of suitable salt. It is then seasoned in the ordinary way. The interior surface of timber dries in advance of exterior one and chances of formation of external cracks are reduced.

iii) **Electrical seasoning:** in this method high frequency alternating current is used to dry the wood. This is the most rapid method of seasoning, but very costly.

iv) **Kiln seasoning:** In this method the timber is arranged in stacks inside kilns and heated air is circulated. This heated air slowly circulates, takes up the moisture from the timber and so dries it. The relative humidity is gradually reduced

v) **Water seasoning:** In this method the timber pieces are immersed in running water of stream. The larger ends of the timber is kept facing on the upstream side. The sap, gum etc. contained in timber is washed away by running water. This process takes 2 to 4 weeks..

Exercise

1. What are the constituents of Portland cement? Explain the functions of each constituent.
2. What are the properties of cement?
3. What are the different IS test for checking quality of cement mortar?
4. What is meant by fineness modulus of aggregate?
5. What are the different test for aggregate?
6. What is meant by grading of concrete?
7. What are the qualities of good aggregate?
8. Explain test for determining crushing strength of aggregate.
9. What are the functions of foundation in building?
10. What are the different types of foundations used in building?
11. Define safe bearing capacity of soil, and explain its importance in foundation design.
12. How are settlement in building measured?
13. Explain Raft foundation. Where it is used? Explain advantages of raft foundation?
14. Describe the different constituents of cement concrete.

15. Enlist the properties of cement concrete.
16. What is meant by proportioning of concrete?
17. Define and explain workability of concrete?
18. What is water-cement ratio?
19. Write short note on ceramic and sound absorbing materials
20. What are the different methods for the seasoning of timber?
21. What the qualities of good timber?
22. Write properties of cement blocks. Is it better than bricks. Why?

SURVEYING

4.1. INTRODUCTION

Surveying is the art of determining relative positions of objects on the surface of earth or above or beneath the surface of earth by means of measurement in the horizontal or vertical plane.

Levelling is the branch of surveying which deals with the measurement of relative heights of different objects on the surface of earth.

The primary object of any survey is the preparation of plan or map. A plan may be defined as the projection of a ground and the features in it on a horizontal plane. Thus plan is a representation of an area and objects in it to some scale. If the selected area is very large and the scale adopted is very small then it is known as map.

Primary divisions of surveying: Surveying may be divided into two general classes: (1) plane surveying and (2) geodetic surveying.

(1) **Plane surveying:** Plane surveying is the type of surveying in which mean surface of earth is considered as plane and curvature of the earth is neglected, as the survey extends over a small area. Surveys covering an area of 200km² may be considered as plane survey. In this survey, line connecting any two points on the earth surface are considered as straight line and the angle between these lines as plane angle. Plane survey is used for layout of canals, highways, railways, construction of bridges, dams, buildings, etc.

(2) **Geodetic surveying:** Geodetic surveying is also called trigonometric surveying. In this survey it is necessary to take into account curvature of the earth. Geodetic survey used when survey extends over large area (greater than 200km²) or accuracy of work required is great. In this survey, line connecting any two points on the earth surface is curved or considered as part of a great circle.

4.2. BASIC PRINCIPLES OF SURVEYING:

The two fundamental principles of surveying are: (i) to work from whole to part and (ii) to fix the position of new stations by at least two independent processes.

(i) To work from whole to part:

The first ruling principle of surveying is to work from whole to part. In plane and geodetic surveying it is essential to establish a system of control points with high precision. To do this the area to be surveyed is divided into large triangles which are surveyed with great accuracy.

are further divided into small triangles with less accuracy. Vertex of these triangles are minor control points. The details can be established by using these minor control points by the method of triangulation or by running minor traverse. Depending up on the importance of work these triangles can be further divided into smaller triangles. This way of working is to prevent the accumulation of error and to control and localise minor errors, within the frame work of the control points.

(ii) To fix the position of new stations by at least two independent points:

The relative position of new point could be located by measurement from two reference points whose positions are already been fixed. Let A and B be the reference points on the ground and 'C' be the new point to be located with reference to A and B. Plot the position of A and B on a drawing sheet to some scale as a and b. For fixing 'C' on sheet there are five methods:

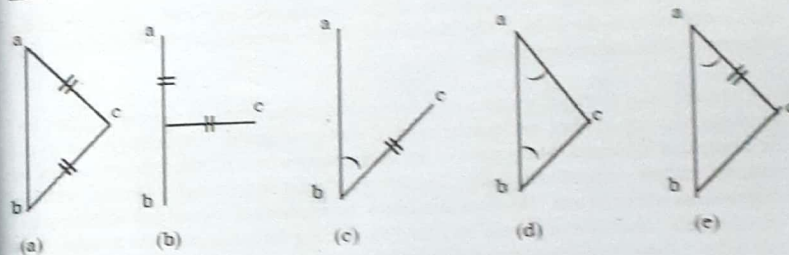

fig. 4.1 Locate point c with reference to a and b

- measure distance AC and BC, draw two arcs from a and b with radius 'ac' and 'bc' as in figure 4.1.a. The meeting point of these two arcs is 'c'. This method is used in chain surveying.
- A perpendicular CD can be dropped on reference line AB and measure distance AD and DC. The point 'c' can be plotted by using set-square. This method is termed as offsetting and is used for locating details. Figure 4.1.b.
- Distance BC and angle ABC can be measured and point 'C' is plotted by means of protractor or by solution of triangles. This method is used in traversing. Figure 4.1.c.
- Distance AC and DC are not measured but measure angle BAC and ABC. Knowing distance 'ab' point 'c' is plotted either by protractor or by solution of triangles. This method is used in triangulation Figure 4.1.d.

- c) Distance AC and angle ABC are measured and point 'c' is plotted by swinging an arc of radius 'ac' from 'a' and mark angle abc from 'b'. The meeting point of angle line and arc is 'c'. This method is used in traversing. Figure 4. 1.e.

4.3. WORK OF THE SURVEYOR

The work of surveyor may be divided into three parts:

- (a) Field work
 - (b) Office work
 - (c) Care and adjustment of instruments.
- a) **Field work:** Field work consist in (i) measuring distances and angles, (ii) locating the details, (iii) recording the details in field notes, (iv) accessing the relative altitude of points and (v) setting out boundaries and objects.
- b) **Office work:** The office work consists of (i) Preparing plan, map and sections from the data collected from the field. (ii) Calculations of areas, volumes and (iii) design of various structures from the collected data.
- c) **Care and adjustment of instruments:** Surveying instruments like theodolite, compass level, etc. are very delicate and must be handled with great care so that various parts may not be strained or loosened. Many parts of the instruments which if once impaired cannot be restored to their original efficiency. The surveyor must be thoroughly familiar with the instruments which he use. He must also know the methods of testing and adjusting the instruments. Instrument should be lifted by placing the hands under the levelling head and before taking the instrument out of its box the correct positions of various parts should be noted, otherwise it may be difficult to replace it. The instrument should be set on its well spread and stable tripod stand and it should be protected from sun, rain and dust.

Surveying is partly an art and partly a science. Qualities of a good surveyor are: (i) Thorough knowledge of the theory of surveying (ii) Skill in its practice (iii) High power of observation and judgement (iv) Personality to organize. This can be acquired by field practice.

4.4. CLASSIFICATION OF SURVEYS

Surveys may be classified in different ways:

1. Classification based on nature of the field.

- (i) **Land survey** - Survey conducted on earth's surface.
- (ii) **Marine or navigation survey** - Survey conducted under water.
- (iii) **Aerial survey** - Survey conducted by Aeroplane in air.

2. Classification based on the object of survey.

- (i) Engineering survey - For determining feasibility of engineering projects.
- (ii) Military or defense survey - For determining points of strategic importance for both offensive and defensive.
- (iii) Geological survey - For determining different strata in the earth crust.
- (iv) Mine survey - For exploring the mineral wealth such as gold, copper, coal etc.

3. Classification based on methods employed in survey

- (i) Triangulation survey
- (ii) Traverse survey

(i) **Triangulation survey:** Triangulation is the basis of trigonometrical or geodetical surveys. Here the area is divided in to network of triangles the length of whose sides are measured directly or indirectly.

(ii) **Traverse survey :** In traverse survey a number of connected survey lines form the framework and the directions and lengths of the survey lines are measured with theodolite and tape. There are two types of traversing (a) open traverse and (b) closed traverse. When chain lines form a circuit which ends at the starting point then it is called closed traverse otherwise it called open traverse.

4. Classification based on instruments employed

- (i) Chain survey
- (ii) Compass survey
- (iii) Plane table survey
- (iv) Theodolite survey
- (v) Tacheometric survey
- (vi) Aerial or Photographic survey
- (vii) Hydrographic survey.

(i) **Chain surveying:** It is the system of surveying in which the sides of various triangles or line connecting stations are measured directly in the field. In this method no angular measurements are taken. Chain surveying is the simplest type of surveying and it is suitable.

- (a) When the ground is fairly level and open ground with simple details.
- (b) When plans are required at large scale.
- (c) When the area is small in extent.

Equipments for chain survey are 20m or 30m chain, 10 arrows, Ranging rod, plumb-bob, cross-staff, peg, field book, etc.

(ii) **Compass survey:** It is the system of surveying in which the direction of survey lines is measured with compass and length of lines measured with chain.

When it is not possible to divide the area into triangles as in chain triangulation, traverse survey is adopted. A traverse is a series of connected survey lines of known length and direction. If compass is used for measuring direction of survey lines in traversing. It is known as compass traversing or compass survey. Compass survey is suitable.

- a) When area cannot be divided into triangles.
- b) When survey details are required along a long narrow strip like road, river, railway etc.
- c) When surveying is done in jungle or in dense forest.
- d) When ground is a large plot with few isolated features.

There are two forms of compass in common use they are prismatic compass and surveyor's compass.

Prismatic compass: Prismatic compass is suitable for rough surveys where speed is more important than accuracy. It is used for preliminary survey for railway, road, military purpose, etc. The results from compass observation may be unrealistic in places where there is more local attraction due to magnetic rock or iron ore deposits. Figure 4.2 shows a prismatic compass.

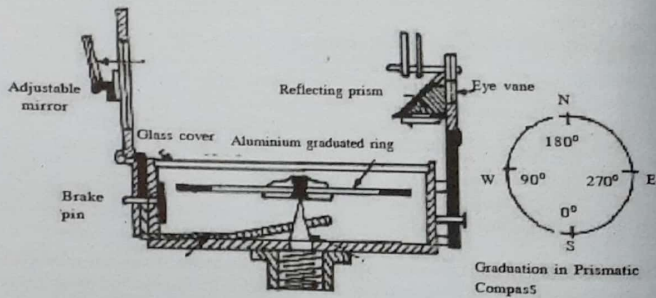

fig. 4.2 Prismatic compass

Surveyor's compass: Surveyor's compass resembles a prismatic compass except that (1) graduations are marked from 0° to 90° in all the direction instead of 0° to 360° in prismatic compass, (2) the graduated card is attached to the box instead of the needle in prismatic compass, (3) zero reading marked on north and south ends, but in prismatic compass zero is marked on the south of the compass, (4) readings are taken against the north end of the needle, (5) the edge bar magnetic needle freely float on the pivot. Figure 4.3 shows a surveyor's compass.

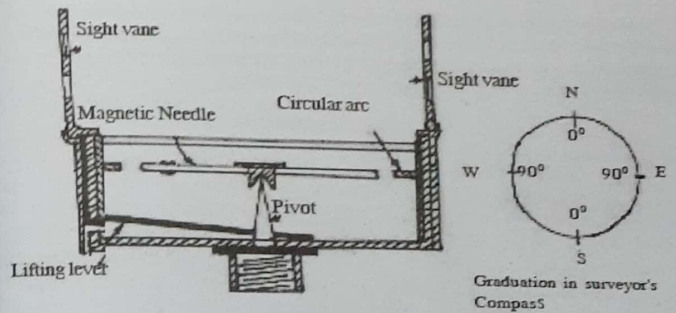

fig. 4.3 Surveyor's compass

(iii) **Plane table surveying:** It is a method of surveying in which field-work and office work are done simultaneously on a plane table. It is a graphical method of surveying. It is suitable for small scale or medium scale mapping in which great accuracy in details is not required as for topographical surveys. It is one of the most rapid method of surveying. There is no chance of missing any necessary measurement, since the map is plotted in the field. It is useful when compass survey cannot be carried out due to heavy local attraction.

Advantages of plane table survey

1. As plotting is done in the field itself, chances of omission of important measurements are avoided.
2. Checking of plotted details can be done easily.
3. In this case numerical values of angles as well as linear measurements are not observed, so the errors and mistakes due to reading recording and plotting are eliminated.
4. Office work is practically reduced to nil.
5. Less costly as compared to other methods of surveying.
6. Since notes of measurements are not recorded, it is great inconvenient to reproduce the map to another scale.

Disadvantages of plane table survey.

1. It is not very accurate.
2. It is inconvenient in rainy season or in wet climate.
3. It requires many accessories on the field.
4. Due to heavyness, it is inconvenient to transport.
5. Since notes of measurements are not recorded, it is great inconvenient to reproduce the map to another scale.

(iv) **Theodolite surveying:** Theodolite is the most intricate and accurate instrument used for measurement of horizontal and vertical angles. It can be used for locating points on a line, prolonging survey lines, finding difference in elevation, setting out grades ranging curves etc. Surveys done with theodolite is known as theodolite surveying.

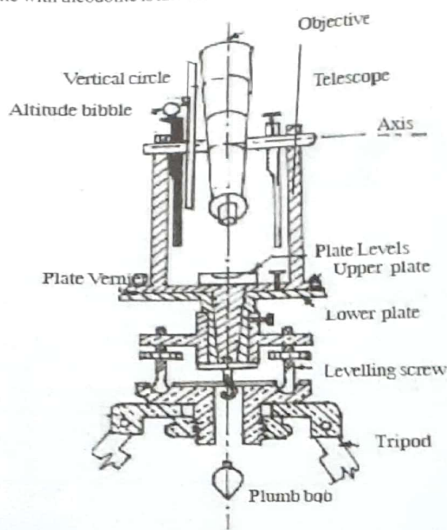

fig. 4.4 Theodolite

Theodolite consists of a telescope by which distant objects can be sighted. The telescope has two distinct motion horizontal and vertical. Motion in horizontal plane can be measured on a horizontal graduated circle by means of a set of verniers. Similarly vertical motion can be measured on a vertical graduated circle by two verniers. Two spirit levels placed at right angles to each other are fixed on the upper surface of the vernier plate for leveling the instrument. A compass is mounted on the centre of vernier plate. (Figure 4.4 shows a transit theodolite.)

(v) **Tacheometric survey:** Tacheometry is a branch of surveying in which the horizontal and vertical distances are determined by angular observations with a tacheometer. observations with a tacheometer. There is no linear measurement. Tacheometry is not as accurate as chaining.

but it is more rapid in rough and difficult countries where levelling is tedious and chaining is inaccurate and slow.

Tacheometric surveying is used for preparing contour plans, hydrographic surveys, location survey of roads, railways etc. Instruments used in tacheometric survey are tacheometer, stadia rod, pegs, ranging rods, offset rods etc.

(vi) **Aerial or photographic survey:** Photographic surveying is a method of surveying in which plans or maps are prepared from photographs taken at suitable camera stations. It is classified into two types (a) ground photogrammetry and (b) aerial photogrammetry. In ground photogrammetry maps are prepared from ground, and in aerial photogrammetry photographs are taken from air. Photo theodolites are used for this survey.

(vii) **Hydrographic surveying:** Hydrographic surveying is a branch of surveying which deals with the determination of position of a body under still or running water, such as a lake, harbour, stream, or river. It comprises all surveys made for the determination of (i) shore lines, (ii) soundings, (iii) characteristics of the bottom, (iv) areas subject to scouring and silting, (v) depths available for navigation, (iv) velocity and characteristics of the flow of water. It is also used for fixing the location of buoys, lights, rocks, sand bars, etc.

4.5. LINEAR MEASUREMENT OF DISTANCES

There are two methods for determining distance (a) direct method and (b) computative method. In direct method distances are actually measured on the ground by means of a chain, tape or other instruments. But in computative method distances are obtained by calculation as in tacheometry and triangulation.

(a) **Direct method for measurement of distances:** Several methods are available for measuring distance, but the method to be selected depends up on the degree of accuracy required.

1. **Pacing:** Where approximate results are required, distance may be determined by pacing. This method consist in walking over the line to be measured and counting the number of paces. Knowing the average length of pace the required distance may be calculated by multiplying number of pace with width of pace. Width of pace may taken as 80cm, and it varies with age, height and physical condition of person. This method is used for reconnaissance surveys, preparation of military plans etc.
2. **Insurumental method:** Some instruments like passometer, pedometer, odometer, speedometer and perambulator may also be employed for finding the distance approximately. Speedometer and perambulator give better results than pacing provided the routeslected is smooth as along a highway.
3. **Judging distance:** This is a very rough method of determining distance. It is used in estimating distances of details in reconnaissance survey.
4. **Time measurement:** The distances are roughly measured by knowing the average time taken per kilometre by a person at walk.
5. **Chaining:** The process of measuring distance with the help of a chain or a tape is called chaining. It is the most accurate and commonly used method for measuring distances. Steel tapes are used instead of chain for measuring small distances below 5m and when great accuracy is required.

4.5.1. Chain Surveying

The simplest kind of land surveying is chain surveying. In this method the area to be surveyed is divided into a number of triangles and sides of each triangles are measured with a tape or chain and angular measurements are taken. Chain survey is suitable when (i) the area is small in extent; (ii) the ground is fairly level and open with simple details; (iii) plans are required on a large scale.

The principle of chain surveying is to divide the area into a frame work consisting of a number of triangles and measure the sides of each triangles, because triangle is the only geometry that can be plotted from the length of their sides. For getting better results in plotting, the frame work should consist of triangles which are as nearly equilateral as possible. The triangle having angles less than 30° and greater than 120° are known as ill-conditioned triangles. A well conditioned triangle with angles between 30 and 120° is always preferred in chain surveying

4.5.2. Terms commonly used in chain surveying

Survey station : survey station is a prominent point at the beginning and end of a chain line. There are two type of stations. (i) main station and (ii) subsidiary or tie station. **Main station** are ends of chain lines which shows the boundaries of the survey and the line joining main stations are called **main survey lines**. **Subsidiary or tie stations** are the points selected on the main survey line where the lines are not right angles to the chain line are called oblique offsets (LM, LN). If length of offset is less than 15m then it is know as short offset and otherwise it is know as long offset.

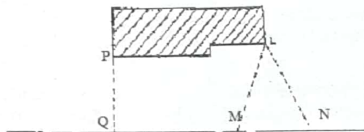

Fig 4.5

15.3. Instrument used for chaining:

The following are the instruments used for chaining:

- | | |
|-------------------------------|-----------------|
| i. Chain | ii. Tape |
| iii. Arrows | iv. Cross staff |
| v. Optical square | vi. Ranging rod |
| vii. Offset rod | viii. Plumb-bob |
| ix. Pegs, wooden hammer, etc. | |

(i) **Chain**: Chains are composed of 100 or 150 pieces of galvanized mild steel wire 4mm in diameter known as links. The ends of each links are bent in to a loop and connected together by three oval rings or circular rings which provide flexibility to the chain and make it less liable to become kinked. The ends of the chain are provided with brass handles for dragging the chain on the ground. It is provided

with swivel joints so that the chain can be turned round without twisting. Length of chain is measured from outside of one handle to outside of the other handle. Brass tags or tallies of distinctive pattern are fixed at various distinctive points of the chain to facilitate quick reading of fraction of a chain in measurement.

Types of chains: There are mainly two types of chains

(a) Metric chain and (b) Non-metric chain

(a) **Metric chain**: The metric chain is 20 or 30 meter in length. Tallies are provided at every five meter and small brass rings at every meter length for counting the number of links. Tallies are of different shapes depending upon their position in the chain. They are marked with letter 'm' for distinguish them from non-metric chain. The full length of chain, 20m or 30m as the case may be marked over the handle frame. In metric chain the length of one link is equal to 20cm.

Steel band chains are steel ribbons of 16 mm width and 20 or 30m length. It is used for accurate survey works. Graduations are marked in metres, decimetres and centimetres on one side and 20cm links on the other side.

(b) **Non-metric chain** : Non-metric chain used in countries where foot is the unit of distance. Examples of non-metric chain are (i) Gunter's chain (ii) Revenue chain (iii) Engineer's chain.

- (i) **Gunter's chain**: Gunter's chain is 66ft long and is divided into 100 links. It is used for measuring distances in miles and furlongs; and for measuring area in acres.
- (ii) **Revenue chain**: Revenue chain is usually used for measuring fields in cadastral survey. It is 33 ft long and is divided in to 16 links.
- (iii) **Engineer's chain** : Engineer's chain is 100ft long and is divided in to 100 links. It is used for all engineering surveys. Engineer's chain is recorded in feet and decimals.

4.5.3. Advantages of chain:

- (a) It is suitable for rough usage.
- (b) It can be easily repaired in the field.
- (c) It can be easily read.
- (d) It has long life.

4.6. LEVELLING

Levelling maybe defined as the art of determining the relative heights or elevation of objects on the earth's surface. Levelling deals with measurement in vertical plane and main purpose of levelling are (i) locating grade line of highways, railway,sewers, pipeline, canal etc. (ii) to calculate volume of earthwork for construction project. (iii) helps to identify drainage characteristic of an area.

4.6.1. Instruments used for levelling

Instruments used for levelling are (i) level and (ii) levelling staff. The level furnishes a horizontal line of sight and levelling staff is used to determine the vertical distances of points below the horizontal line of sight.

The level: It consists essentially of (i) The levelling head (ii) telescope (iii) level tube or bubble tube and (iv) tripod.

Levelling head is used to bring the bubble in its centre of run. The telescope which provides the line of sight. Level tube for making the line of sight horizontal and tripod for supporting the instrument. Triangles with angles greater than 120° are known as ill-conditioned triangles. A well conditioned triangle with angles between 30° and 120° is always preferred in chain surveying.

4.6.2. Types of level

Following are the different type of levels:

- | | |
|-----------------------------|-------------------------------------|
| 1. Dumpy level | 5. Modern (Tilting) level |
| 2. Wye or Y level | 6. Automatic level |
| 3. Cooke's reversible level | 7. Digital level (refer chapter 18) |
| 4. Cushing's level | |

- Dumpy level:** Dumpy level is a simple, compact and stable instrument. The telescope is rigidly fixed to its support. It can neither be rotated about its longitudinal axis nor it can be removed from its supports. It has greater stability of adjustment than Y-level but its permanent adjustment take much time.
- Wye level or Y level:** The Y-level is a very delicate instrument. The telescope of this level can be removed from its supports and reversed end for end. The essential difference between the dumpy level and the wye level is that in dumpy level telescope is fixed to spindle but in wye level telescope is carried in two vertical 'Y' supports. It can also be revolved about its longitudinal axis in this. The main advantage of Y-levels and other reversible levels are (i) the ease and rapidity with which permanent adjustment can be tested and (ii) the adjustment can be made indoors.
- Cooke's reversible level:** Cooke's level combines good features of both Dumpy and Y-levels providing a stop flange screw the telescope can be rotated about its longitudinal axis in the sockets can also be withdrawn from the sockets and replaced end for end.
- Backsight (B.S):** It is a staff reading taken on a point of known reduced level (R.L) as on a bench mark or a change point. It is the first staff reading taken after the level is set up and levelled.
- Intermediate sight (I.S):** It is any reading other than foresight and backsight taken on a point of unknown R.L from the same set up of the level. All readings taken between the back sight and foresight reading are called intermediate sight reading. In figure 4.6 readings to B, C and E are intermediate sights from O_1 and O_2 . In one setting of the level there is only one foresight (last reading) and backsight (first reading) but there may be any number of intermediate sights.
- Foresight (F.S):** It is a staff reading taken on a point whose reduced level is to be determined. It is the last staff reading taken before the shifting of the level.
- Height of instrument (H.I):** It is the elevation or reduced level of the line of collimation of the instrument is correctly levelled.

- Bench mark:** It is a fixed reference point of known elevation. The R.L. of a bench mark above a certain assumed datum is determined and recorded together with its sketch and description for the future reference. In figure 4.6, A is the benchmark.

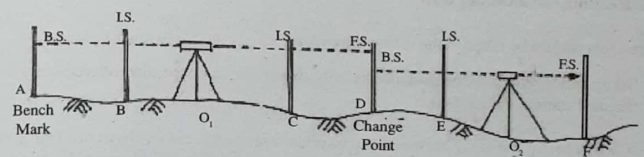

Fig 4.6

- Focussing:** Focussing means to set the eyepiece and the object glass at proper distance apart for the clear vision of the object sighted. The focus of the objective and that of the eye-piece must coincide with the cross-hair of the diaphragm, as the diaphragm is placed at the common focus. This can be done by first focussing the eye piece and then the object-glass.
- Change point (C.P):** It is an intermediate staff station on which two sights F.S and B.S are taken and it is used for the purpose of changing the position of level from O_1 to O_2 . Here D is the change point.

4.6.3 Adjustments of a level:

Each instrument need two types of adjustments (1) Temporary adjustments and (2) Permanent adjustments. Temporary adjustments are those which have to be performed at each set-up of the level. Permanent adjustments are made only when the fundamental relation between some parts or lines are disturbed.

4.6.4. Temporary adjustment:

The temporary adjustment for a level consists of the following:

- Setting up the level
- Levelling up
- Elimination of parallax

Setting up the level: Setting up of the instrument includes (i) fixing the instrument on stand and (ii) levelling up the instrument on tripod. For fixing instrument on stand release the clamp screw of the instrument, hold it in the right hand and fix it on the tripod stand by turning round the lower part of the instrument with left hand. Then screw the instrument firmly. The tripod legs are so adjusted that the instrument is at the convenient height and the tribrach is approximately horizontal. If the tripod legs are not adjusted to full length may spoil the whole work. Least count of this staff is 5mm. Metre staff is marked in red letters and decimetres in black letters. It is made of well seasoned timber.

ordinary levelling, the staff is waved slowly towards the level and backwards and the least reading is taken to avoid these errors. Sometimes the staff is held inverted when the point is above the plane of sight, here too waved the staff about the station and the least reading is taken

4.6.5. Reading the levelling staff

Staff reading should be taken in the following order:

- Set up and levelled the instrument carefully, direct the telescope towards vertically held staff at the staff station and focus it.
- Always bring the staff between the two vertical hairs, and always used the portion of horizontal cross-hair between them for reading the staff as the horizontal cross hair may be slightly inclined. By means of the vertical hairs, the level man can see whether the staff is or not plumb. If there is only one vertical hair a reading be taken at the intersection of horizontal and vertical hair.
- Observe whether the bubble is central. If not, centre it by using one of the foot screws nearly in line with the telescope, and note the reading at which the horizontal cross hair appears to cut the staff. First count the red figure (metres), then the black figures (decimetres) and finally count the spaces. Record the reading.

If the graduation on the staff are inverted they look erect when seen through the telescope. Then the staff should be read upwards. But, if the graduations are erect they are inverted, then the staff should be read downwards.

4.7. PRINCIPLES OF LEVELLING

The level is set up and correctly levelled, the line of collimation will be horizontal, and when the telescope is rotated about its vertical axis, it will revolve in a horizontal plane known as plane of collimation. All the staff readings taken with the telescope will be the vertical measurement measured downwards from this plane as shown in fig. there are two essential steps in levelling. The first step

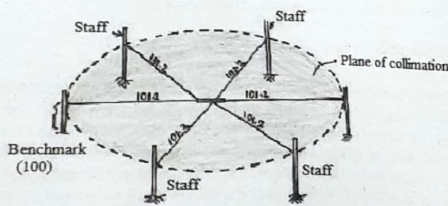

Fig 4.7

to find the elevation or reduced level (R.L) of the plane of collimation (H.I) of the level by taking backsight (B.S) on a bench mark.

$$\text{Height of instrument (H.I)} = \text{R.L of Bench mark} + \text{B.S}$$

The second step is to find the elevation or reduced level (R.L) of any other point by taking a reading on the staff held at that point.

$$\begin{aligned} \text{R.L of a point} &= \text{Height of instrument} - \text{Foresight towards the point} \\ \text{or R.L of point} &= \text{Height of instrument} - \text{Intermediate sight toward the point} \end{aligned}$$

4.8. Classification of levelling

Levelling may be classified in to two types

- Simple levelling* and (ii) *Differential levelling*.
- Simple levelling* : It is the simplest operation in levelling when it is required to find the difference in elevation between two points, which are visible from a single position of the level.
- Differential levelling*: Differential levelling is used to find the difference in elevation between two points when a) They are far apart, or (b) the difference in elevation between them is too great, or c) there are obstacles intervening. In all these cases, it is necessary to set up the level in several positions and to work in a series of stages.

4.9. Reduction of levels

There are two systems for working out the reduced levels of points from the staff readings taken in the field. (1)The height of collimation system and (2)the rise and fall system

- The height of collimation system*: In this method the height of the instrument (H.I) is calculated for each setting of the instrument, and then calculating reduced levels of points with reference to the respective plane of collimation.

To begin with, the height of collimation for the first set up of the level is determined by adding the backsight to the reduced level of the bench mark. The reduced level of the intermediate points and first change points are obtained by subtracting the staff readings taken on these points from the height of the instrument. When the instrument is shifted to the second position a new plane of collimation is set up. The new height of instrument is the sum of reduced level at change point and backsight from the new station to change point. The reduce levels of the successive points and the second change point are found by subtracting their staff readings from the height of instrument. After completing the reduction of the level the accuracy of the arithmetic work should be checked by using the formula.

Sum of Backsight - Sum of Foresight = Last R.L. - First R.L

Exercise

1. What is the object of surveying. Explain the two basic principles of surveying?
2. Write down the classification of survey based on the instrument used.
3. Write down the duties of a surveyor?
4. Write down the classification of survey based on the instruments used.
5. What is meant by temporary adjustment of levels?
6. What is the difference between simple levelling and differential levelling?
7. What is meant by temporary adjustment of level?

BUILDING CONSTRUCTION

5.1 FOUNDATION

After conducting survey and investigation, it is necessary to find out the exact location of the building in the selected plot. Next step is to do design the building based on the bearing capacity of soil, load coming on the structure etc, after that we can proceed to the construction activities.

Alignment of building to be marked on the plot after that do the following steps:

- | | |
|---------------------------------|--|
| 1. Earth work excavation, | 2. Foundation and basement |
| 3. Wall and lintel | 4. Roofs, plastering of walls and roof |
| 5. Flooring | 6. Doors and Windows |
| 7. Electrification and plumbing | 8. Painting |

Foundation is the lowermost part of a building which transmits the load of building to the underlying earth. The major functions of the foundation are:

- i) It spread the load coming on it over a large area at uniform rate, so that the pressure on the soil below the foundation does not exceed its allowable bearing capacity.
- ii) Foundation distribute non-uniform load of the super structure evenly on the subsoil hence it minimize chances of differential settlement.
- iii) It provides stability against undermining or scouring by flood water or burrowing animals.
- iv) It provides safety against sliding.
- v) It provides a level surface for the construction of the super-structure.

5.1.1. Bearing Capacity of Soil

The soil supporting a building must be strong enough to carry the super imposed load. After the preliminary and detailed investigation of the type of soil, depth of bed rock, elevation of ground water etc, the next step is to select a suitable foundation to be used for the building. The depth to which foundation is to be taken and its bottom dimension so that it can safely transmit the load from building to underlying soil without any failure or significant settlement. For the determination of this, a knowledge of the safe allowable pressure on the soil is necessary. The ability of the soil to support the super imposed load without excessive settlement or failure is called **Bearing capacity** of soil.

Dimension of foundation should be such that it can safely transmit the load from building to the soil without any failure or significant settlement. The gross pressure intensity at which the soil fails is called **Ultimate bearing capacity**.

Safe bearing capacity : It is the maximum pressure which the soil can carry without the risk of shear failure.

Usually adopted factor of safety is 2 to 3. Safe bearing capacity is used for the design of foundation and up to this load there is no settlement for the soil. Allowable bearing capacity is the maximum allowable net load intensity that can be applied to soil.

5.1.2. Methods for improving Bearing Capacity of soil

Following are the different methods for improving bearing capacity of soil:

1. Increase the depth of foundation : In normal cases soils have got greater bearing capacity at deeper levels due to the weight of the overlying material.
2. By draining the soil: Water content in soil will decrease its bearing capacity. By draining sandy soil and gravel by gravity pipe drainage system or by installing shallow tube wells, we can improve the bearing capacity.
3. By compacting the soil: Compaction of the soil reduce the open space between the individual particles and they are less liable to settlement. Thus by compaction we can increase the bearing capacity of soil.
4. By grouting: Cement mortar can be injected under pressure in to the subsoil to seal off voids in between subsoil and foundation.
5. By confining the soil: Sheet piles are driven around the structure to form an enclosure which will prevent the movement of soil.
6. Chemical treatment: Chemical solution are injected under pressure into the soil. This chemicals form a gel and keep soil particles together to form a compact mass.
7. Using Geotextiles: Geotextiles are porous fabrics made of natural or synthetic materials such as polythylene, polyester, nylon, coir etc. Geotextiles have high tensile strength hence they act as a reinforcement for soil.

5.1.3. Excavation for foundation

The trenches for foundation of walls or columns should be excavated to the exact width, length and depth as in building drawing details. The width marked in drawing are corresponding to the bottom level. If soil is firm and depth is not excessive, the sides of excavation may remain vertical without support for a few days till concreting is done and masonry is raised to the ground level.

When excavation is deep and soil is not firm, the sides of trenches must be suitably sloped or they must be supported by some arrangement of boarding called timbering or shoring. When depth of foundation exceeds 2m, shoring the sides is more economical than providing slopes on either side.

For clayey soil, which is firm but likely to develop vertical cracks in the sides by exposure to the sun and wind, and slip, simple poling boards of size 20cm x 4cm are placed vertically in pairs, on each side of trench and strutted apart by stout pieces of bullies of about 10cm diameter called struts. For loose soil, poling boards must be placed closer together perpendicularly with struts as shown in figure 2.2.

In loose soil, sides of trenches cannot stand unsupported for a height greater than 25cm, the boards are held immediately against the sides of trenches and placed horizontally. In such cases, the excavation is carried to a depth of 20 to 25cm and is immediately supported by planks placed against the opposite sides and held in position by struts. (refer fig 3..3).

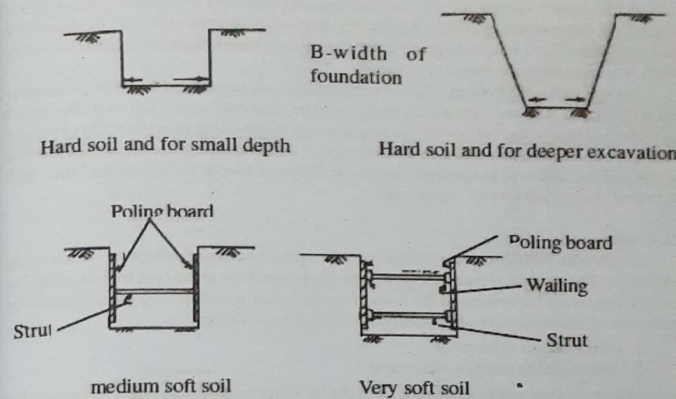

fig 5.1 Excavation for foundation in different soil

The next 20 to 25cm are excavated and protected in the same way. When five or six planks are inserted on each side, vertical planks are added to keep them together and more struts are added with the existing strut to prevent sliding of soil.

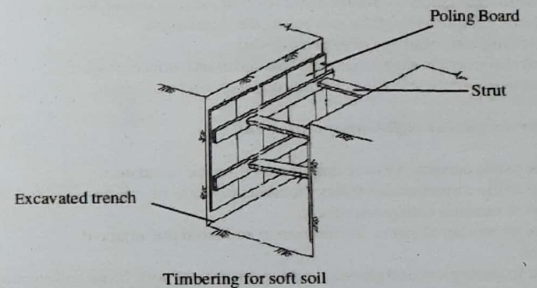

fig 5.2 Timbering for Excavation

In very loose soil, poling boards have to be kept side by side otherwise soil will come through the intervening space. In addition, waling members are used to give additional support and these are adequately strutted. For deep excavation in loose soil, planks of 100 mm thick and 18 to 22 cm wide with pointed ends are driven deeper than the desired excavation depth, waling and struts are used as usual.

For soft rocks, the bottom of the trench should be struck with an iron bar or a hammer and if in any part it sounds hollow, that part should be excavated and filled with concrete. If the surface of rock at the bottom of trench is sloping, it should be made level by chiselling. If the slope is considerable and is in the direction of longitudinal axis of the trench, it should be cut and divided into horizontal terraces at different levels. In this manner the waling system of excavation is to be completed.

5.1.4. Settlement

Loads from buildings are transmitted to the underlying soil through the bottom of the foundation. The soil below the foundation gets compressed due to the load transmission. The vertical downward movement of the base of the structure is called settlement of buildings. Settlement of foundation can be generally classified into two types.

1. Total or equal settlement
2. Differential or unequal settlement.

In case of equal settlement every part of the building settles by an equal amount, but differential settlement different portion of building settles unequally and may causes cracks of roof, wall and foundation.

Reasons for equal settlement:

- a. Due to consolidation of soil under the foundation.
- b. Due to fluctuation of ground water level in loose granular soil.
- c. Elastic compression of the soil below the foundation.
- d. Swelling and shrinkage of expansive soil.
- e. Soil movement in earth slopes, eg. land slides and surface erosion.
- f. Due to adjacent excavation, mining, under ground erosion etc.

Reasons for unequal or differential settlement:

- a. Due to non uniform pressure distribution from the foundation.
- b. Due to the construction of heavy loaded buildings near light weighted buildings.
- c. Due to unequal expansion of soil.
- d. Due to overlap of stress distribution in soil from the adjacent structures.
- e. Due to geological and physical nonuniformity of soil. If the soil in one portion soft and for the other side hard rock then to pressure from foundation soft soil settle down but hard rock may not have any movement..

5.1.5. Classification of Foundations

Depending upon the depth foundations can be broadly classified into shallow and deep foundation. If depth of foundation is less than or equal to the width then the foundation is known as shallow foundation. When depth is more than width, it is known as deep foundation.

Depending upon the nature of load and type of supporting soil there are three types of foundations (a) spread footing (b) pile foundation and (c) pier foundation. In this classification spread footing comes under the classification of **shallow foundation** and pile and pier comes under **deep foundation**.

$$\text{Width of Shallow foundation} = \frac{\text{Load per metre length of wall}}{\text{allowable bearing capacity of soil}}$$

Depth of foundation from Rankine's formula for loose soil,

$$\text{depth} = \frac{p}{\omega} \left[\frac{1 - \sin \phi}{1 + \sin \phi} \right]^{-2}$$

- where,
- p - Safe bearing capacity of soil in kg/m^2 .
 - ω - Weight density of soil in kg/m^3 .
 - ϕ - Angle of repose of soil
- | | |
|------------|--------------------|
| for clay | ϕ - 15 to 20° |
| for sand | ϕ - 15 to 30° |
| for gravel | ϕ - 35 to 45° |

5.1.6. TYPES OF FOUNDATIONS

(a) Spread foundation or Shallow foundation:

In this type of foundation the load is spread over a large area and thus the intensity of load transmitted to the soil is less than its allowable bearing capacity. Different types of spread foundation are:

- i) Wall footing
- ii) Isolated or column footing.
- iii) Combined footing
- iv) Cantilever footing
- v) Continuous footing
- vi) Inverted arch footing
- vii) Grillage foundation
- viii) Raft or mat foundation
- ix) Stepped foundation

i) **Wall footing (also known as spread footing):** Footing provided under a wall is known as wall footing or spread footing. It may be simple footing or stepped footing. For light load simple footing is provided which is having only one foundation block. For heavy load total width of footing may be very high and this is attained in three or four steps are called stepped footing

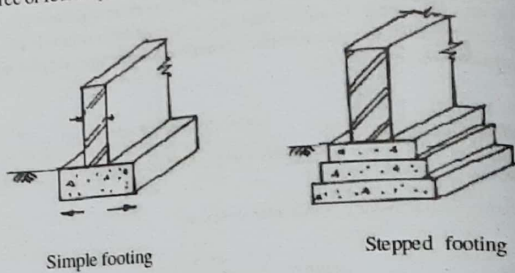

fig.5.3 Wall footing

ii) **Isolated or column footing:** Isolated or Column footing is used to support isolated columns. Column footing may be either stepped or sloped footing. Reinforced cement concrete footing is provided when column should carry heavy load otherwise plain concrete footing is sufficient. Thickness of isolated footing depends up on the load acting on the column and width of the footing. If size of footing is very large we prefer stepped or sloped foundation to reduce the cost of foundation. In all these cases load transmitted through the foundation to soil should be less than bearing capacity of soil. (refer fig 5.4)

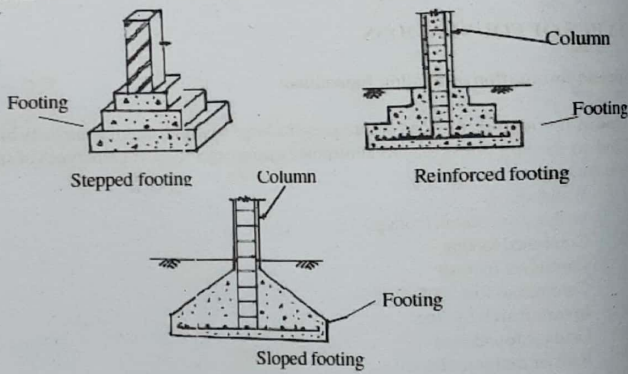

Fig 5.4 Column footing

iii) **Combined footing:** A common footing constructed for two or more column is known as combined footing. It is provided when isolated footings of individual column overlaps or when external column is situated near the boundary. Combined footing may be rectangular or trapezoidal in plan view. Rectangular footing is provided when load acting on two columns are almost equal. Trapezoidal footings are recommended in two situations (a) loads acting on one of the column is very high (b) when one of the column is very close to the boundary (in that case it is not possible to extend the footing slab beyond the boundary of the site) and (c) when the bearing capacity of soil is very low and requires more area for individual footing. Shape of combined footing is designed in such a way that center of gravity of footing is in same vertical line as the centre of gravity of the loads. This is for preventing overturning of the foundation.

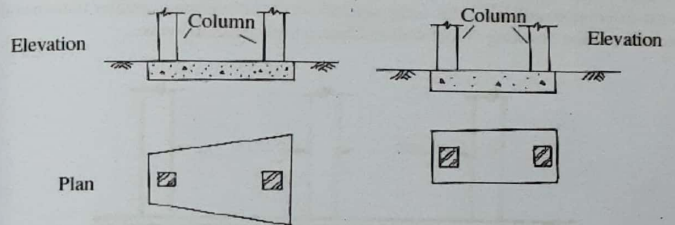

Fig 5.5 Combined footing

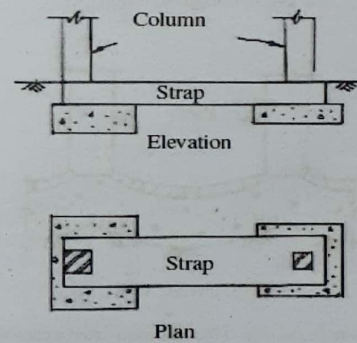

Fig 5.6 Cantilever footing

iv) **Cantilever footing:** This type of foundation is used when it is impossible to place a footing directly beneath column due to limitations of land, filled up land, adjacent building or due to eccentric loading conditions. This type of foundation is used when the two columns are at a reasonable distance and combined footing is not economical. Here columns are connected by a strap or cantilever beam. The load from the exterior column or column resting on filled up land is partially transferred to the interior column through the strap. Usually a reinforced cement concrete beam act as a strap.

v) **Continuous footing:** If a single continuous R.C.C slab acts as a foundation of two or more columns then that footing is known as continuous footing. This type of foundation is used when there are two or more columns in one row and footings of individual columns overlap. It is safe against differential settlement (i.e. settlement of one of the column is greater than the other which may cause cracking of roof wall and foundation) and earth quake.

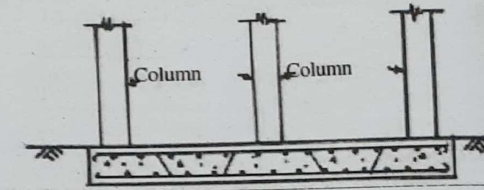

Fig 5.7 Continuous footing

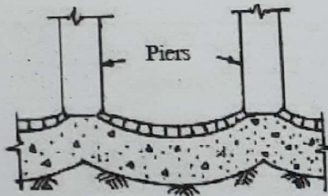
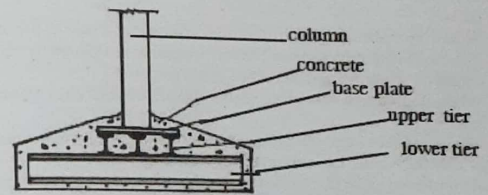

Fig 5.8. Inverted Arches

vi) **Inverted arch foundation:** In this type of foundation inverted arches are constructed between two walls at the base as shown in figure. It is suitable for soil of low bearing capacity and where depth of foundation is to be kept low. The load which is transmitted to the soil through the

arches and gets distributed over a wider area. Hence the soil can bear the pressure safely. In this case, the end column must be strong enough to resist the outward pressure caused by the arch action.

This type of foundation is suitable for bridges, culverts, Check dams, reservoirs etc.



Elevation

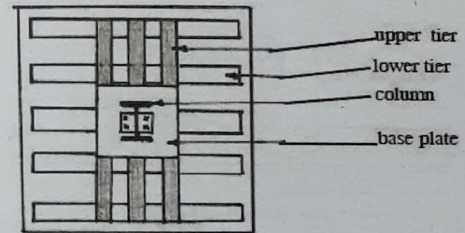

Plan

Fig 5.9 Grillage Foundation

vii) **Grillage foundation:** Grillage foundation is used to transfer heavy loads from steel columns to soil having low bearing capacity, or where the depth of foundation is limited to 1 to 1.5m. It is constructed with Rolled Steel Joists (R.S.J.) which are placed in single or double tier. In double tier lower tier must be arranged perpendicular to the upper tier and spacing of R.S.J. is 1.5 to 2.0 times width of flange or 30cm. On the upper tier a base plate is provided on which column is resting. All these members are embedded in concrete for protecting it from corrosion. Grillage foundation is useful for structures having very high concentrated load like theatres, factories, town halls, community halls, etc. (Fig 5.9)

viii) **Mat or Raft foundation:** Mat foundation is also known as flat foundation. It is a concrete slab which cover the entire area below the building and support all columns and walls. If the column loads are heavy reinforced concrete slabs of enough thickness are provided.

Mat foundation used in the following situations:

- (a) When the soil is soft clay or made up land or marshy land with low bearing capacity.
- (b) Building loads are very high so that individual columns footing may overlap each other.
- (c) Where there is chances of differential settlement or possibility of earth quake.
- (d) It is used in highly compressible soil to reduce settlement by equalising the weight of structure and weight of excavated soil.
- (e) When columns are very close so that spread footing cover more than half of the area.

Mat foundation can face large settlement without causing any harm to the super structure because in this case the whole structure is resting on a single foundation. When the load transferred to the foundation is excessive, thicker concrete beams may be used to connect the columns for better rigidity of structure (fig 5.10). Weight of solids removed should be more than the combined weight of building and raft.

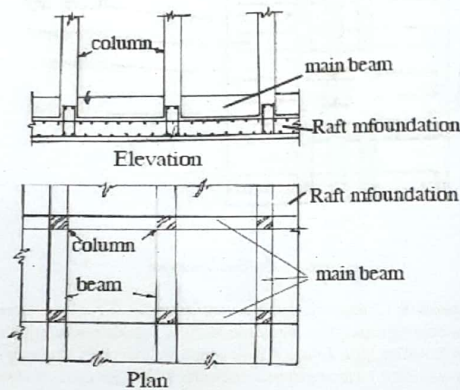

Fig 5.10 Raft Foundation

ix) Stepped foundation: When the ground is sloping (slope $>10^\circ$) it is uneconomical to provide foundation at the same level. In such cases stepped foundation is provided. The overlap between two layers of foundation slab must be greater than the depth of concrete slab. The minimum depth of foundation slab is 80cm below the ground surface.

(b) Pile foundation:

Pile may be defined as a long vertical member made up of timber, steel, concrete or R.C.C or a combination of any of these used to transfer the load of structure to soil. The foundation which consists of piles is known as pile foundation. It is a deep foundation used for buildings if heavy loads are to be transferred through soil strata of low bearing capacity. Pile may driven vertically or slightly inclined, if the pile is inclined then it is known as battered pile.

Depending up on the material used piles can be classified as wooden pile, concrete pile, steel pile, R.C.C pile, pre-stressed concrete pile etc.

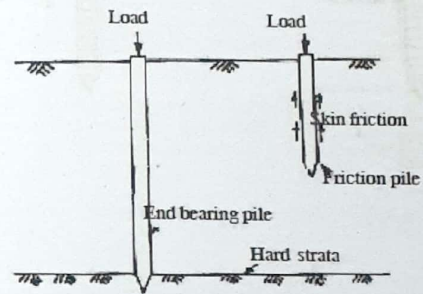

Fig 5.11 Pile Foundation

Depending upon the load carrying capacity it is classified as **load bearing pile** and **non-load bearing pile** (sheet pile). **Load bearing piles** are capable of carrying load and they are further classified in to **end bearing pile** and **friction pile**. If a load bearing pile rest on a hard strata as shown in figure and transfer load to that strata, such piles are known as **end bearing piles**. When loose soil extend to a great extend, piles are driven up to such a depth that friction between pile and surrounding soil will resist the load, such piles are known as **friction piles**. Concrete piles can be broadly classified in to two types (i) Pre-cast concrete piles and (ii) Cast-in-situ piles.

(i) **Pre-cast concrete piles:** This type of piles are cast in a yard, cured and then driven into the ground. They are commonly of square section with chamfered corners. Other shapes are also available but octagonal shape has a better appearance and reinforcement can also be placed easily in it. Concrete mix generally used for pre-cast piles are 1:2:4 or 1:1½:3. Diameter of piles vary from 25 to 60cm. Length of pile vary from 3 to 30m, but generally less than 5 metres are not used. while driving these piles into hard soil, cast iron or mild steel shoes of 20 cm depth 15 cm width are provided at the lower end.

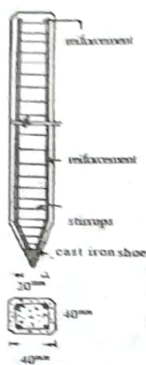

fig. 5.12 Precast concrete pile

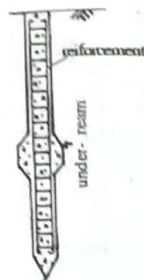

fig.5.13 Under-reamed pile

The major advantages include:

It can be examined and make necessary repairs work before end use. The positioning of reinforcements can be maintained. These piles can be easily driven under water also.

(ii) **Cast-in-situ piles:** Cast-in-situ piles are cast at the place where they have to function by driving a casing in to an excavated hole and filling up this casing with concrete. If the casing is kept in position after placing the concrete then it is called cased cast-in-situ piles. If the casing is withdrawn after placing concrete then it is called uncased cast-in-situ piles.

Different types of uncased cast-in-situ piles are:

1. Simplex pile
2. Pedestal pile
3. Vibro pile
4. Under-reamed pile.

Out of these under reamed piles are special

Under-reamed piles: Structures built on expansive soil often crack due to the differential movement caused by the alternate swelling and shrinking of soil. An under reamed pile provides a satisfactory solution to this problem. With one additional under-ream (bulb) the

bearing capacity is increased by 50%. Refer fig 5.13

The principle of this type of foundation is to anchor the structure at a depth where the ground movements due to changes in moisture content are negligible. Single under-reamed piles may be provided for foundation of lighter structure and double under-reamed piles for heavy structures. For double under-reamed piles, spacing between two under-reamings are kept equal to 1.5 times the under-reamed diameter. Diameter of under-reamed portions are normally 2 to 2.5 times the diameter of the shaft and do not exceed three times. Under reamed piles can carry heavy lateral load so it can be used as foundation of retaining structures, tower footings, abutments, etc., where lateral load is heavy.

Other types of Piles are:

Batten pile : Batten piles are also known as spur piles. They are constructed to resist horizontal loads and are usually driven in an inclined direction. Used for supporting dolphins for mooring ships, for resisting horizontal earth pressure.

Sheet Piles: It consists of interlocking steel plates of different shapes so that it can be easily driven into the ground or river bed and the space in between two layers are filled with sand. They are commonly used to retain soil in structures like wharves, dams and other water retaining structures.

Fender piles: Fender piles are driven in front of wharves or other coastal structures to protect them from impact of ships.

Compaction piles: Piles which are driven into the coarse grained soil for compacting the soil for increasing its density are called. Compaction piles. They are not designed to carry any load but simply used to improve the bearing capacity of soil. Coconut logs are also used as compaction pile. Some times after driving the compaction pile to the required depth, it is removed and the hole is filled with sand or plain lean concrete mix.

C) PIER FOUNDATION:

Pier foundation used when hard strata are available at a reasonable depth and the load to be transmitted is large. Pier foundation is shallower than pile and it is cast-in-situ type. It may be a huge cylindrical masonry or a hollow vertical shaft filled with inert material. It is used as foundation of bridges, towers, etc

Well foundation is generally used for foundation under water, such as ducks, bridges etc. It will not be a solid structure like that of pier but will be hollow inside, resembling a well. The load is transferred through the wall around called staining. The well is constructed and brought to the site. Then it is gradually driven down by digging the soil from inside. The bottom is plugged with concrete and the hollow portion is filled with sand. The whole well is then covered with a cap above which the super structure will be constructed.

5.2. STONE MASONRY

Stone masonry is the art of building structures using stones. Materials required for stone masonry are stones and mortar. Mortar acts as a bonding material in stone masonry and it may be cement mortar or lime mortar. Building stones are obtained from rock.

Classification of stone masonry

Stone masonry is broadly classified into two types:

(1) Rubble masonry and (2) Ashlar masonry.

1. **Rubble masonry:** In rubble masonry stones of irregular shapes and sizes are used. Strength of this masonry depends upon the proper filling of gaps between stones, quality of mortar and number of through stones. It is cheaper than ashlar masonry.

2. **Ashlar masonry:** In ashlar masonry, stones of rectangular or square shapes are used. The course may not be of same height. Height of stone varies from 25 to 30cm. It is much costlier than rubble masonry due to dressing and polishing of stones. But compared to other masonry quantity of mortar used is very small and it is stronger than other bonds.

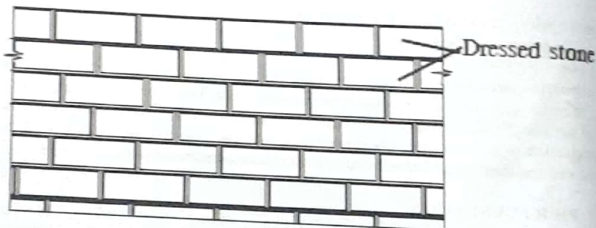

Fig. 5.14. Ashlar masonry

3.5.1. Different types of rubble masonry are:

- a) Random rubble masonry
- b) Coursed rubble masonry
- c) Dry rubble masonry
- d) Polygonal rubble masonry
- e) Flint rubble masonry

(a) Random rubble masonry:

In this type, stones of irregular shapes are used but they are arranged so as to give a good appearance. Here thickness of mortar joint should be less than 12mm and face stones are chisel dressed. This type of masonry can be used for residential building, compound walls, garages, etc. Random rubble masonry can further be classified into (i) Coursed random rubble and (ii) Uncoursed random rubble.

(i) **Coursed random rubble masonry:** In coursed random rubble masonry, stones are laid to maintain level courses. In each course, headers of full course height and consisting of hammer dressed stones are placed at certain intervals, known as cross stones. Each header has a width not less than its height and project in to the wall at least three times its height.



Fig. 5.15 coursed random rubble masonry



Fig. 5.16 uncoursed random rubble masonry

(ii) **Uncoursed random rubble masonry:** Uncoursed random rubble masonry is built without dressing. The stones are of different shape and mason selects the stones at random from heap and place them to form a strong bond. Large stones are used at corners and jambs to increase strength. Through stone is used for every square metre of face work. Uncoursed random rubble masonry affords a very rough appearance.

(b) Coursed rubble masonry:

Coursed rubble masonry is commonly adopted in construction of residential buildings, public buildings, piers and abutments for ordinary bridges. This type of masonry is made up of a facing comprising of hammered squared stones with a backing of rubble masonry. Stones in each course may not be of same height but all courses should be of same height. Minimum height of course is limited to 15cm. The through stones provided to bind the two faces together are spaced at 1.8m apart. Height of quoins are same as the height of the course and thickness of joints should not exceed 10mm. Depending upon the dressing and finishing of stones, coursed rubble masonry is further subdivided into first class, second class and third class masonry.

In **first class coursed rubble masonry**, generally all the courses and all the stones are of same height. And minimum height of course is limited to 15cm.

In *second class coursed rubble masonry*, courses and stones may not be of equal height. Only two stones are to be used to make one course as shown in figure. Thickness of mortar joint is 12mm.

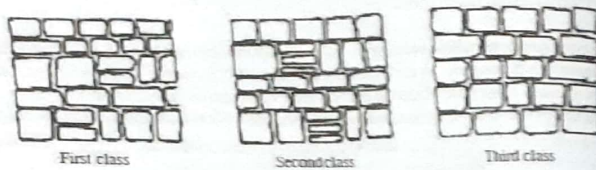

fig. 5.17 coursed rubble masonry

In *third class coursed rubble masonry* courses and stones may not be of equal height. Only three stones are to be used to make one course as shown in figure 5.17. Thickness of mortar joint is 16mm.

c) Dry rubble masonry:

Dry rubble masonry is similar to third class coursed rubble masonry but no mortar is used in the joints. Hollow space between the stones must be tightly packed with chips of stones. Through stones are placed at interval of 2m to strengthen the masonry. This is the cheapest method of construction, but requires more skill. Dry rubble masonry is used for the construction of retaining wall, pitching earthen dams, canal slopes, etc.



fig. 5.18 Dry rubble masonry

d) Polygonal rubble masonry:

In polygonal rubble masonry stones are roughly dressed as irregular polygon. One through stone is inserted to run through the wall if the wall is less than half metre in thickness. Here the face joints are running in an irregular fashion. More skilled labour is required for the construction of this masonry. Polygonal rubble masonry is used for construction of

abutments, retaining walls, etc. Fig 3.11 shows polygonal rubble masonry.

e) Flint rubble masonry:

In flint rubble masonry most of the stones used are flint. Flints are hard and irregular shaped nodules of silica, width and thickness varies from 8 to 15cm and length 15 to 30cm. For strengthening flint masonry lacing courses are provided at a distance of 1 to 2m. Buildings near coast are constructed of walls with rounded flints procured from the beaches. The walls are about half metre in thickness and may be built with a facing of cut flints and a backing of undressed flint.

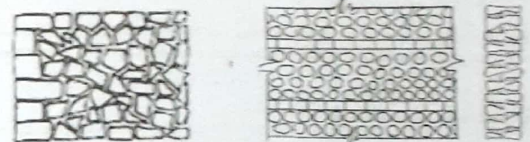

Fig 5.19 Polygonal rubble masonry fig 5.20 Flint rubble masonry

5.3. BRICK MASONRY :

Brick masonry is the art of building structures using bricks 'or' the systematic arrangement of laying bricks and bonding them with mortar to form a unified mass, which can transmit the superimposed load without failure, is termed as brick masonry. As bricks are of uniform size, they can be properly arranged and due to it's light weight no lifting appliance is required for the construction. Bricks do not require dressing hence the art of laying bricks is so simple that brick work can be carried out even with the help of unskilled labourers. Brick masonry is used for the construction of foundation, walls, retaining walls, columns, culverts, floors, etc. The strength of masonry depends upon the quality of brick and type of mortar used. Commonly used mortars are lime mortar, cement mortar, cement-lime mortar, gauged mortar and surkhi mortar. Proportion of lime and sand in lime mortar 1:1; proportion of cement and sand in cement mortar 1:4 to 1:6; cement, proportion of lime and sand in gauged mortar 1:1:5

5.8. Terms used in brick masonry

1. **Header** : The end surface of brick when it is laid flat is known as header (9 x 9cm)
2. **Stretcher** : The side surface of the brick visible in elevation when brick laid flat is known as stretcher (19 x 9cm)
3. **Course** : A complete layer of bricks laid on the same bed is known as course. Thickness of a course is equal to the thickness of a brick plus the thickness of one mortar joint.

4. **Frogs:** These are depressions provided in the face of the bricks. Frogs used to form a key with mortar to prevent sliding of bricks and for reducing the weight of bricks. Nine centimetres high brick should have a frog of 10 x 4 x 1 cm size on one of its sides.
5. **Bed:** The bottom surface of brick when it is laid flat is known as bed (19 x 9cm).
6. **Bat:** A portion of a brick cut across the width of brick is known as bat. Brick bats of different sizes and shapes are available like 1/2 bat, 3/4 bat and bevelled bat. In case of 1/2 and 3/4 bat length of brick bat are equal to 1/2 and 3/4 times the length of brick. Bevelled bat is obtained by cutting a brick obliquely across the width of a brick.
7. **Closer:** A portion of a brick cut longitudinally with one long face uncut. It is used to close up the bond at the end of brick course to prevent the joints of successive courses to come in a vertical line. The different types of closers are:

a) **Queen closer:** Queen closer is a half brick cut longitudinally, as in figure 4.4. A queen closer is generally placed next to the first brick in a header course to obtain necessary lap.

Different conditions for good bond:

- a) Length of one brick should be equal to two times the width of brick + thickness of mortar joint.
- b) The overlap between two adjacent brick should be greater than or equal to one fourth the length of brick.
- c) Vertical joints of alternate layers should lie along the same vertical line.
- d) Number of brick bats used for the construction should be less.

5.3.1 Types of brick bonds:

Following are the different types of bonds used in brick masonry.

- | | |
|---------------------|-----------------------|
| a) Stretcher bond | f) Raking bond |
| b) Header bond | g) Dutch bond |
| c) English bond | h) English cross bond |
| d) Flemish bond | i) Facing bond |
| e) Garden wall bond | j) Zig-zag bond |

a) **Stretcher bond:** In stretcher bond all bricks are laid with their lengths in the longitudinal direction of the wall. Only stretcher are visible in elevation thus this bond is known as stretcher bond. This bond is suitable for half-brick thick partition walls. And it is not suitable for thicker walls due to lack of proper bond age across the wall

b) **Header bond:** In header bond, all the bricks are laid as headers towards the face of the wall. This brick bond is suitable for one brick thick walls and also for the construction of curved walls. As in figure alternate courses of each side are started with two 3/4 bats for

breaking the continuity of vertical joints in adjacent courses. This bond does not have strength to transmit pressure in the direction of the length of the wall. Hence it is not suitable for load bearing walls.



fig. 5.21 Stretcher bond

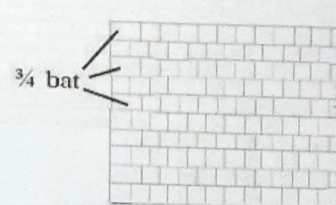

fig. 5.22 Header bond

c) **English bond:** In English bond, alternate courses of stretchers and headers are laid. A queen closer is placed after the first header in the header course to stagger the vertical joints of successive courses. If the wall thickness is even multiple of 1/2 brick the same course shows header or stretcher in both front and back elevation. This type of bond is commonly used in all modes of construction.

d) **Flemish bond:** In Flemish bond, stretchers and headers are laid in the same course. A header in any course is centrally supported over a stretcher below it. For this closers are inserted in alternate courses next to the quoin header for breaking the vertical joints in successive courses. In this bond headers and stretchers appear in the same course alternately on the front and back faces.

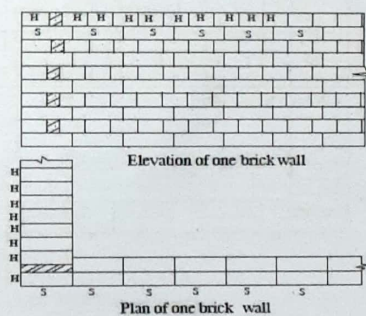

fig. 5.23. English bond one brick wall

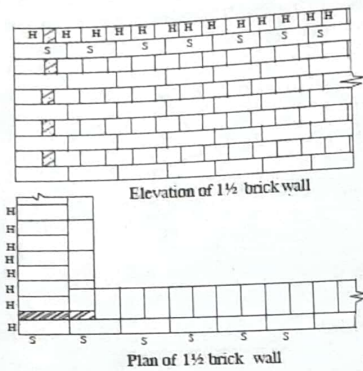

fig. 5.24. English bond 1 1/2 brick wall

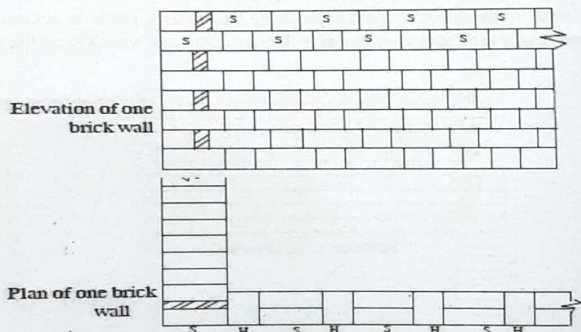

fig. 5.25. Flemish bond one brick wall

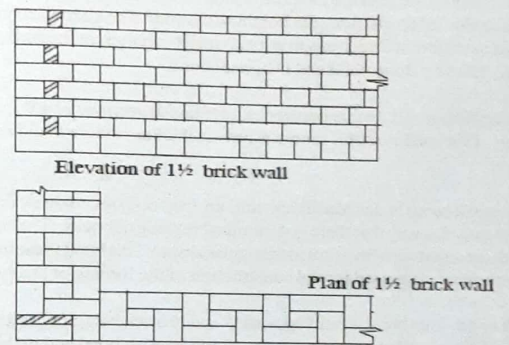

Fig. 5.26. Flemish bond 1 1/2 brick wall

5.3.2. Comparison of English and Flemish bond:

1. English bond is found to possess more strength than the Flemish bond for walls having thickness greater than 1 1/2 bricks
2. Flemish bond gives better appearance than English bond, but it is not so strong as the English bond.
3. It is possible to use broken bricks in the form of brick bats in case of Flemish bond.
4. Construction with Flemish bond requires skilled labour.

e) **Garden wall bond:** This bond is used for the construction of compound wall, garden wall, boundary wall, etc. There are two types of wall (i) English garden wall bond and (ii) Flemish garden wall bond.

(i) **English garden wall bond:** In this bond one header course is provided to three or five stretcher courses. The quoin headers are placed in alternate courses and a quoin closer is placed next to the quoin header in a header course to develop necessary lap.

(ii) **Flemish garden wall bond:** In this bond each course contains one header to three or five stretchers. A 3/4 bat is placed next to the quoin header in every alternate courses to develop necessary lap. This bond is also known as the scotch bond or sussex bond. If each course contains one header to three stretchers as in figure, it is known as *monk bond*.

f) **Raking bond:** In very thick walls, the number of headers used is more than the number of

stretchers, thus it is weak in the longitudinal direction. As a remedial measure raking courses are laid at certain intervals along the height of the wall. The alternate courses of raking bonds are placed in different directions to get maximum strength in the wall. Two types of raking bonds are - Herring Bone bond and Diagonal bond.

(i) **Herring Bone bond:** In this bond bricks are laid at an angle of 45° from the centre in both directions. This bond is useful for walls having thickness more than four bricks, for paving etc.

(ii) **Diagonal bond:** In this bond bricks are laid diagonally at certain inclination, the inclination is selected in such a way that there is minimum breaking of bricks. The small triangular spaces at the ends are filled with brick cut to triangular shape. This bond is useful for walls, which are 2 to 4 brick thick. It is used for the construction of the footing of heavy walls.

g) **Dutch bond:** This bond is built up with $\frac{3}{4}$ and $\frac{1}{2}$ brick bats along with regular headers and stretchers. This is really a modified form of the English bond and in this bond the junctions are stronger than other bonds. In this bond alternate courses are headers and stretchers.

h) **English cross bond:** English cross bond is similar to English bond with only difference that every alternate stretcher course has a header placed next to the quoin stretcher.

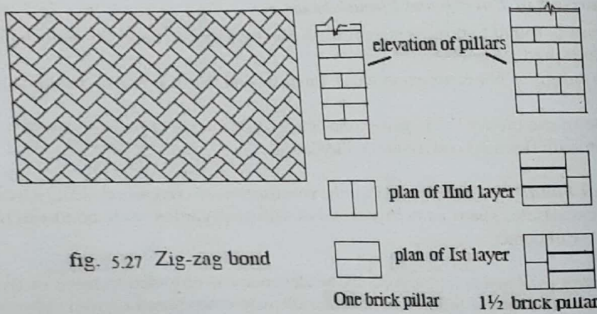

fig. 5.27 Zig-zag bond

fig. 5.27 Zig-zag bond

fig. 5.28. Brick bond in pillars

i) **Facing bond:** Facing bond is used when the facing and backing bricks are of different size and shape, and when facing bricks are expensive. In this bond, a header course is placed after several stretcher courses. Distance between successive header courses depends upon

thickness of backing and facing bricks. i.e. it is the least multiple of thickness of backing and facing brick. If 9cm is thickness of backing brick and that of facing brick be 10cm. Then distance between successive header course is L.C.M of 9 and 10 i.e. 90cm.

j) **Zig-Zag bond:** Zig-zag bond is similar to Herring Bone bond with only difference that in this bond bricks are laid in zig-zag fashion. This is commonly used for paving the brick floors. fig 5.27.

Bonds in Brick Pillars

The bonds in brick pillar masonry for one brick and one-and-a half brick pillars are shown in fig 5.28. For good strength of the masonry adjacent vertical joints should not be along same vertical line. Brick pillars with cavity inside is also constructed for reducing the cost of construction.

5.4. Cement Block Masonry

Cement blocks are now used in building construction because of its light weight easy availability and due its economy compared to bricks, stones and massive concrete blocks. Cement blocks are very light due to the presence of cavity inside it. Air pockets inside the block gives thermal and sound insulation to the room for a certain extend.

Sizes - Originally only one or two types of blocks were available, but now a variety of blocks are manufactured. Standard size of block used in wall construction is 440 x 215mm with two cavities.

5.4.1. Properties of Cement blocks :

- Appearance - This concrete blocks are light-gray incolour and have rough texture and is suitable for most types of plastering.
- Sound insulation and acoustic control - Air voids present inside the cement blocks offer good soud and thermal insulation
- Fire resistance - Cement blocks are classified as non-combustible. 215mm thick blocks provide fire resistance of 3 hrs and 3hr load bearing capacity.
- Durability - Cement blocks do not rot or decay and are resistant to freeze-thaw cycles. They have good resistance to sulphate attack.
- Workability - Cement blocks are not so easy to handle as in case of brick due to its large size but by placing a single block it will cover about four times the area covered by brick.
- Compressive strength- Compressive strength is 2.9N/mm^2 .
- Thermal conductivity - Thermal conductivity is 0.11W/mK .
- Cement blocks can be recycled.

5.4.2. Cement blocks Construction:

Cement blocks arranged systematically and bedded together in mortar to form a homogeneous mass capable of withstanding and transmitting forces without failure is called cement block masonry. Due to large size of cement hollow blocks, the work can be finished very faster than the ordinary bricks. Due to the presence of hollow or cavity inside each block give good insulation against heat, cold, sound and damp.

For the construction of cement block wall, spread mortar on the foundation concrete to about 1.5cm thickness. Lay first cement block at the corner with its hollow face down as shown in figure 4.24, and press it on the mortar so that the thickness of joint between cement block and foundation is 1cm. Then arrange other cement block in the same line and level with the corner block, fill the gap between cement blocks with cement mortar, as in brick work. For laying second course spread mortar over the first course to a depth of 1.5cm and repeat the same procedure as that of 1st course.

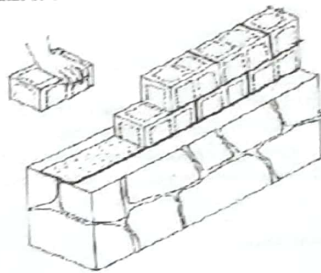

fig. 5.29. Hollow brick masonry

5.5. ROOF

Roof is the topmost portion of a building and it is constructed in such a way as to give protection to building from rain, snow, hail, wind, direct sunlight, etc. There are different types of roof depending upon the shape and material used.

5.5.1. Classification of roof based on shape:

- a) Pitched or sloping roof.
- b) Flat roof
- c) Curved roof.

Roof selection depends on the climate, availability of material, importance of building etc. Pitched roof have sloping top surface thus they are suitable for places where rainfall or snowfall is heavy. Flat roof is suitable for moderate rainfall. Curved roofs have their top surface curved in the form of shells and domes. Thus they are further classified into shell roof and domes. Curved roofs are suitable for public building to develop architectural effect.

5.5.2. Pitched or sloping roof

Pitched roof have sloping top surfaces and they are used in coastal region where temperature is more or less equable, but for heavy rainfall. Different slopes can be given to pitched roofs depending upon the area covered, availability of materials, quantity of light and ventilation available equipments, etc. The simplest type of pitched roof is shed roof or lean to roof which slopes in one direction and can be used for covering verandah portion, shed and extension. Commonly used pitched roof is gable roof which slopes in two direction. If roof slopes in two direction then it is known as hip roof. Gambrel is like gable roof, slopes in two direction but there is break in slope. Mansard roof slopes in four direction but slopes are not continuous.

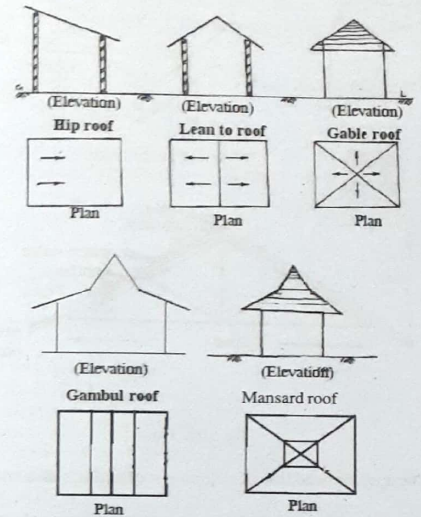

fig. 5.30

Technical Terms Used in Wooden Pitched Roof :

Span: Span or clear span is the clear distance between the supports as in figure. Effective span is the centre to centre distance between the supports.

Rise: Vertical distance between ridge and wall plate is known as rise of a pitched roof.

Pitch: Pitch is the inclination of sides of the roof with respect to the horizontal plane and can be represented in degrees or as a ratio of rise to span.

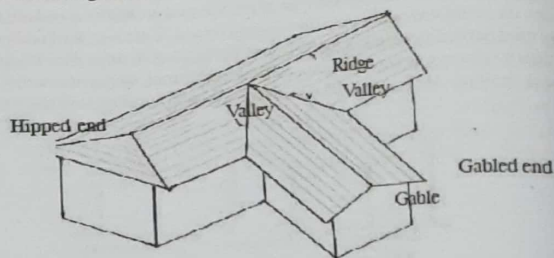

fig. 5.31 View of pitched roof

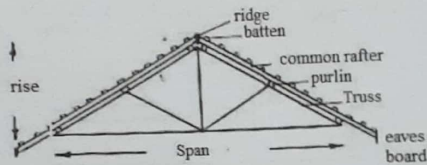

fig. 5.32. Truss

Ridge: Ridge is the apex or head line of a sloping roof and it is also known as apex line.

Hip: Hip is the external angle formed at the intersection of two roof slopes.

Gable: If roof slopes in two directions, the closing wall in that portion may be a combination of triangular and rectangular wall. The triangular upper part of the wall formed at the end of pitched roof is known as gable.

Valley: When two roof surfaces meet together at an angle less than 180°, a valley is formed.

Eaves and eaves board: Eave is the lower edge of a sloping roof. Eaves board is a thin board

of wood or metal sheet provided along the eaves connecting the ends of common rafter. It is used for better appearance.

Wall plates: The member placed just above the wall to receive the common rafters is known as wall plate. This member transfers load from common rafter to wall.

Purlins: Purlins are wooden members, which are used to connect trusses and to support common rafters. Purlins are placed horizontally over the principal rafter.

Rafters: Rafters are inclined members placed above the purlins and extend from ridge to eave. Common rafters are intermediate rafters, which give support to the roof covering. Spacing of common rafter is 30 to 45 cm. Rafters provided at the junction of two roof slopes is known as hip rafter. Rafters shorter than common rafter are known as jack rafter. Principal rafter is the top inclined member of truss.

Truss: Truss is a framework of triangles, which transfer the load of roofing material, other members of roof, wind load, etc. to wall or column.

Battens: Battens are small cross-sections of wood which are fixed on common rafter to support roofing materials like tiles, A.C. sheet, G.I. sheet, etc.

Cleats: Cleats are small pieces of steel or timber, angle or channel section used to connect purlins to principal rafter.

5.5.3. Types of Pitched Roof

Following are the different types of pitched roof:

- (a) Lean-to roof or sloping roof.
- (b) Couple roof.
- (c) Couple close roof.
- (d) Collar beam roof
- (e) Collar and tie roof } Double or purlin roof
- (f) King post truss
- (g) Queen post truss
- (h) Mansard truss } Truss
- (i) Bel-fast truss
- (j) Steel truss
- (k) Composite truss

a) **Lean-to roof or shed roof:** This is the simplest type of sloping roof and it is used for covering verandah, sheds and outhouses connected to main building, etc. Here on upper side

common rafters are supported on a wall plate which in turn rest on a projecting corbel stone from the wall. The lower side rest on the wall plate as in fig. In this case roofing material rest on battens, battens on common rafter and common rafter on wall plate. Maximum span of this roof is 2.5m.

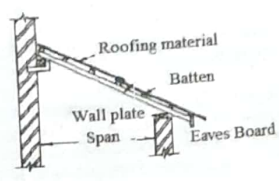

fig. 5.33 Lean-to roof

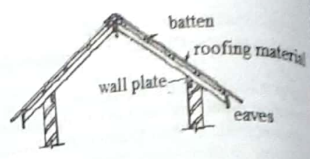

fig.5.34 Couple roof

- b) **Couple roof:** It is formed by a pair of inclined rafters, centre ridge piece (at top) and wall plates (at bottom) for supporting the whole roof. Here two battens are supported on common rafters and roofing material on battens. Span of couple roof is limited to 3.5m.
- c) **Couple close roof:** This type of roof is similar to couple. The only difference is that here the two rafters are connected by a wooden member which acts as a tie. Tie prevents the outward spreading of roof and can also be act as a support for ceiling. These roofs can be economically used for spans up to 4.2 meters
- d) **Collar beam roof:** Collar beam roof is a modified form of couple close roof. The members are same but just raising the position of tie beam as shown in figure, then the tie beam is known as collar and roof as collar beam roof. It is used to increase the height of room and for spans between 4 to 4.5m.

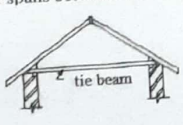

fig. 5.35 Couple close roof

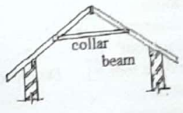

fig. 5.36 Collar beam roof

- e) **Collar and tie roof (purlin roof):** The designed size of rafters for span greater than 3.0 meters is uneconomical. To reduce the size of rafters, intermediate supports, called purlins are introduced under the rafter as in figure. Such roofs with intermediate purlin support is known as collar and tie roof or purlin roof or double roof. This type of roof can be economically adopted for spans up to 4.8 metres.

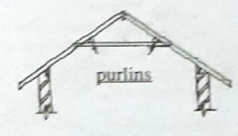

fig. 5.37 collar and tie roof

- f) **King post truss:** When span is greater than 5.0 metres or where intermediate supports for purlins and ties are not available, trusses are used. The triangular shape of truss frame offers greater rigidity and here load transmission to wall is vertical. In king post truss, the central vertical post called king post provides support for the tie beam. Two inclined members provided on either side of king post are known as struts and are used to prevent the principal rafter from bending at the centre. King post truss can be economically used for spans 5 to 8 metres.
- f) **Queen post truss:** In queen post truss there are two vertical posts known as queen posts, two principal rafters, struts, tie beam, purlins and a straining beam. Straining beam is a horizontal beam, which keeps the upper end of queen post in position and to counteract the thrust of struts. A straining sill is provided on the tie beam. A queen post truss can be used for roof spans varying from 8 to 13metres. There are combination of king and queen posts for spans up to 18metres.

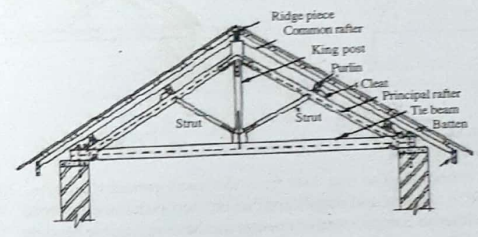

fig. 5.38 King post truss

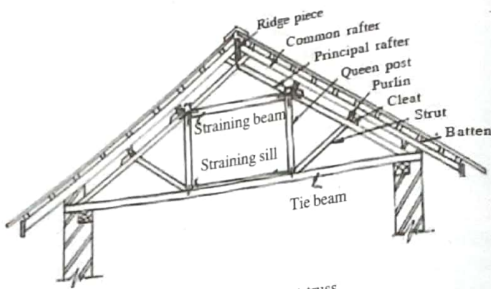

fig. 5.39 Queen post truss

g) **Mansard truss:** It is a combination of king post and queen post but the truss has two pitches. The upper portion resembles a king post and lower portion resembles a queen post. Here there are two tie beams, one king post, two queen posts, four principal rafters and two struts. Pitch of upper part is 30 to 45° and of lower part is 60 to 70° .

h) **Bel-fast truss:** Bel-fast truss is also known as bowstring or latticed roof truss. This truss consists of thin sections of wood to form a bow shaped top chord, and can be used for long spans up to 30m , with light roof covering materials. The rise at the center of the truss must not be more than $1/8^{\text{th}}$ of span.

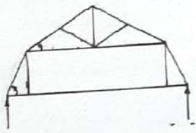

fig. 5.40 Mansard truss

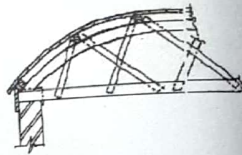

fig. 5.41 Bel-fast truss

i) **Steel truss:** It is economical to use steel truss for spans greater than 12m . Mild steel sections are available in all sizes and shapes and can be used as members of truss. Members of steel roof truss is either in compression or tension and have negligible bending. The stress in each member depends upon the span, type of truss, roof slope, roofing material and center to center distance between the trusses. Different types of steel trusses are (a) Open truss (b) North light truss (c) Bow-string trusses and (d) Arched rib truss.

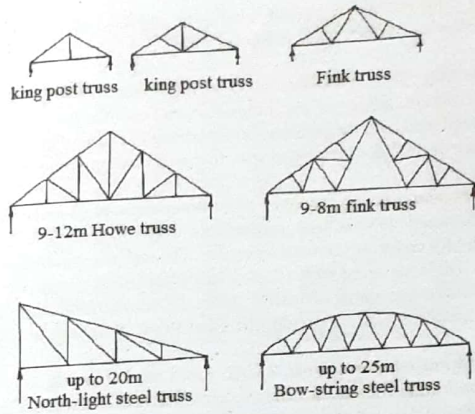

fig. 5.42 Steel Truss

Advantages of steel trusses are :

- (i) Pre-cast structures of desired dimensions are available in market.
- (ii) Termite and fire proof
- (iii) Light in weight and can be fabricate in any desired architectural form.
- (iv) Strong, durable and long life.
- (v) Quickly and easily installed.

5.5.6. Types of Flat Roofs or Terraced Roof

This type of roofs are provided in areas which have less rainfall or have no snowfall. In flat roof too we have to provide some slope on surface to drain out the rain water otherwise there may be leakage of water.

Commonly used flat roofs are

- (a) madras terrace roof (b) Bengal terrace roof (c) reinforced brick cement roof (d) Reinforced cement concrete roof and (e) Filler slab.

5.12.1 Types of flat roofs:

Following are the different types of flat roofs:

- a) **Madras terrace roof or wooden flat roofs:** These types of roof having slope less than 1 in

100 and it slope towards either side as shown in figure and it is widely used in Madras. Step in construction of madras terrace roofs are as follows:

b) Bengal Terrace roof: This roof is used for covering verandah portion. It consist of rafters with spacing 30 to 50 cm. having slight inclination and one end penetrated in to wall as in figure. Battens are placed over these rafters with spacing 15 cm, and over that flat tiles laid in mortar. The surface of this roof is finished with fine jelly concrete or two courses of flat tiles.

c) Reinforced brick cement roof: It consist of reinforcement, brick and concrete. Bricks are laid horizontally between the steel bars and concrete mix is inserted in the joints to fill the gap between bricks and for covering the reinforcement. The slab is supported on the wall and the top surface of the slab is plastered with a 2cm thick cement mortar and over that apply two layers of hot bitumen for water proofing. Over the bitumen coat apply one more coat of cement paste of thickness 5cm. Provide sufficient slope at the top surface for drainage of rainwater.

d) Reinforced cement concrete roof: R.C.C. roofs are becoming very common in the construction of modern buildings. It is made up of concrete and steel. There are two types of roof slab (i) one way slab, when the ratio of length of room to width is greater than 2.0. (ii) Two way slab, when this ratio is less than 2.0. For one way slab reinforcement to be run parallel to the shorter span. In two way slab main reinforcement runs parallel to both sides of the room, and at corners suitable mesh reinforcement to be provided to resist temperature stresses.

Reinforced cement concrete slabs are easy to construct and it provides a very smooth finishing surface. The thickness of roof slab depends on the type of concrete used, span, floor load etc. If slab rest on wall, for the free movement of slab, the top of the wall is covered with a layer of smooth plaster and a thick coat of bitumen applied on this before casting the slab. If the building is a framed construction, then it is necessary to build the slab monolithically with the supporting beams and column.

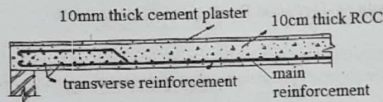

fig. 5.43 Reinforced cement concrete roof

e) Filler Slab: Filler slab is a concrete slab in which the bottom portion of the slab is replaced by flat clay tiles or mangalore pattern tiles. In case of concrete slab top portion under tension and bottom portion of the slab under compression. The tensile force acting on the bottom portion of the slab carried by reinforcement so concrete in that portion can be replaced by cheaper filler material like tiles. This mode of construction will reduce the construction cost.

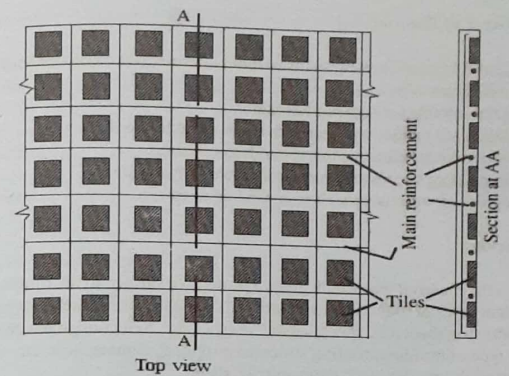

fig. 5.44 Filler slab

Procedure for the construction of filler slab:

- Step 1: Above the formwork, steel reinforcements of designed size are tied together to form a grid.
- Step 2: Pairs of clay roofing tiles (the tiles are stacked back to back to create an air gap between them) are placed in the gap between the reinforcement in line as shown in figure 5.44.
- Step 3: Pour freshly prepared concrete in between the reinforcement and tiles and compact it carefully. Level the concrete surface and cured it for 14 days.

Advantages of filler slab:

- 1. It provide better insulating property
- 2. Amount of concrete can be reduced to 50%.
- 3. Sound like RCC slab and more attractive than ordinary slab.

5.5.7. Advantages of flat roof

- (i) It does not require any false ceiling.
- (ii) Its construction and repair are simple.
- (iii) It is easier to make a flat roof fire resistance.
- (iv) It provides architectural beauty to the building.
- (v) The construction work of upper floor can be easily started.
- (vi) A flat roof is more stable against high winds.
- (vii) It can be used as floor in case of two storied building.
- (viii) It possesses good insulating property.

5.5.8 Disadvantages of flat roof

- (i) It cannot be used for long spans without intermediate beams and columns.
- (ii) Its initial cost is high.
- (iii) It is not suitable for high rainfall region.
- (iv) It is difficult to trace and rectify the leakage in flat roof.
- (v) Cracks may develop due to temperature variation.
- (vi) Proper surface slope is to be provided to drain off rain water.
- (vii) Progress of work is very slow compared to trusses.

5.6. Roof coverings

Roof covering is the material that which gives a protective surface to the roofing structure. There are different types of roof covering materials are available like thatching, tiling, slate, glass, asbestos sheet, G.I. sheet, asphalt mastic, etc. Selection of covering material depends on the type of building, roofing structure provided, climate, cost, etc. Commonly used roofing materials are tiles, A.C. sheet and G.I. sheet.

5.6.1 Asbestos Cement Sheets (AC Sheets):

Asbestos cement is a mixture of cement and asbestos. Asbestos cement sheets are suitable for roofing, and are available in two varieties (a) with corrugation and (b) with wider channels as in figure. Thickness of A.C. sheet is 3mm to 6mm and spacing of purlin is 1.0 to 1.5m. Overlap, 15cm on ends and 5cm on sides.

Galvanized iron screws of minimum 5cm length with lead or bitumen washers can be used for fixing sheet on purlins. Length of A.C. sheet varies from 1.5 to 3.05m. Straight and corrugated sheet of various sizes are available in market. Length of A.C. sheet varies from 1.5 to 3.05m.

They are now become popular due to following reason: light weight, low cost, tough durable, water tight, fire resistant and available in bigger size unlike like tiles so supporting frame too is simple and light. They do not require any protective paint and no maintenance cost.

A.C. sheet is impervious, and is fire and vermin proof. They are breakable and heavier than G.I. sheets. One of the disadvantage of A.C. sheet is that it transfers heat and cold easily.

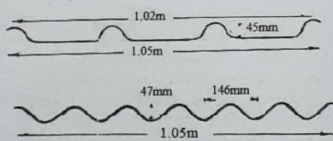

fig. 5.45 Asbestos cement sheet

5.6.2 Galvanized Corrugated Iron Roofing:

Corrugated iron sheet galvanized with zinc, to protect it from rusting in wet condition, is known as galvanized corrugated iron sheet. Even if appearance of corrugated iron sheet is not good it is widely used due to its light weight, fire proof and its durability. Width of sheet is 60 to 85cm and length 1m to 3.5m. The thickness of sheet is 0.15 to 1.8mm. spacing of purlin is 2 to 2.5m. G.I. nails or screws are used for fixing sheets. End overlap of G.I. sheet is 7.5 to 15cm and side over lap one corrugation. Weight of G.I. sheet covering is lighter than A.C. sheet roof and tiled roof thus lighter supporting structure is enough which reduce the cost of roof.

Table 5.7. Comparison between A.C. & G.I. Sheet

Sl. no	A. C. Sheet	G.I. Sheet
1	Manufactured from asbestos fiber and cement.	Galvanizing wrought iron plates.
2	Heavy weight, thickness 3mm to 6mm.	Light weight, thickness 0.15 to 1.8mm.
3	Durable, fire resistant and sound proof.	Easily corroded, not able to resist fire and not sound proof.
4	Not affected by acids	Affected by acids and fumes.
5	Less initial and maintenance cost.	High initial and maintenance cost.
6	Look neater and cleaner	Look dull

5.6.3. PVC (polyvinyl chloride) roof membranes

PVC roof membranes have the longest track record of any thermoplastic membrane, with the first PVC-based systems installed in Europe in the early 1960s. Reinforced PVC roof membranes have many advantages. Besides the important feature of heat-welded seam technology, PVC or vinyl roof membranes offer many other inherent features.

Additional features are:

1. Can be made in a spectrum of colors including reflective white.
2. It has high resistance to puncture and impact.
3. An excellent resistance to flame exposure and subsequent fire propagation.
4. It has proven durability against rooftop soiling and contamination.
5. Good low-temperature flexibility and high-temperature tolerance.
6. Vinyl roof membranes are very user friendly.

7. They are installed by a variety of attachment methods.
8. Vinyl roof membranes are aesthetically appealing after installation.

Vinyl is the best known thermoplastic roof membrane. "Thermoplastic" means that when heated sufficiently, the material temporarily changes from a solid to a semisolid state, enabling the sheets or panels that are overlapped to be fused together and return to a solid state upon cooling, yielding one continuous membrane. It is this feature that enables the seams and overlaps of vinyl roof membranes to be fused or heat welded together.

In addition to fire resistance, vinyl membranes also meet or exceed other industry performance standards that involve water leakage, puncture resistance, hail resistance, wind uplift resistance and so on. Vinyl roof membranes also stand up exceptionally well to heavy rainwater, which often remains despite efforts for positive drainage, and to a variety of typical roof top contaminants, such as air pollution, bird droppings, acid rain, etc. Over a long period of time, vinyl roof membranes have earned the recognition of being a proven and versatile thermoplastic for rooftop applications.

5.6.4. PVC Corrugated sheets:

PVC corrugated sheets are made up of Poly Vinyl Chloride plastic and other plastic like poly carbonate. These types of sheets with different colours are now available in market. These sheet has a service temperature range of -20 to 60°C. Compared to other roofing material they are light weight, durable, fire resistant, rust free and give colour full appearance to building.

5.6. FLOORS

Floors divide a building into different levels, one above the other for the purpose of creating more accommodation within a limited space. Depending upon the position of floors, floor can be divided into three types (i) ground floor, (ii) basement floor and (iii) upper-floors.

- (i) **Ground Floor:** Floor constructed just above the ground level is called ground floor.
- (ii) **Basement floor:** Floor constructed below the ground level that is in basement building is called basement floor.
- (iii) **Upper Floors:** Floors above the ground level are called upper floors. It is further divided into first floor, second floor, etc depending upon the location of upper floor above the ground floor.

Floor consists of two components

- (a) a sub-floor or base course and (b) floor covering or flooring.

(a) **Sub-Floor or Base course :** This is the bottom most portion of a floor. The purpose of this component is to impart strength and stability to support the floor covering all other superimposed loads. Materials used for sub floor construction are brick, stone, wood and concrete.

(b) **Floor Covering or flooring :** This is the covering over sub-floor and is meant to provide a hard, clean, smooth, impervious, durable and attractive surface to the floor. Materials used for the finishing of floors are brick, stone, tile, concrete, timber, mosaic, terrazzo, marble, rubber, cork, linoleum, glass, etc.

Preparation of bed for flooring:

Ground floor or basement floor directly rest on the ground. So ground should be strong enough to support the floor. The ground surface to be levelled compacted and watered before flooring. In the case of loose soil, some times broken bricks and laterite may be used for stabilizing the soil, prepared surface to be levelled compacted and watered for avoiding differential settlement of floor. Otherwise cracks may developed on the floor due to settlement of ground. It is essential to provide a porous layer of inert materials like sand or gravel just above the prepared bed. This porous layer check the rise of subsurface water in to the floor.

Types of floors:

Various types of floors commonly used are:

- | | |
|-------------------------------------|------------------------------------|
| (1) Basement or ground timber floor | (4) Hollow tiled and ribbed floor. |
| (2) Single joist timber floor | (5) Jack arch floor |
| (3) Flat slab floor | (6) R.C.C floor |

Out of these RCC floor and Flat slab roofs are most popular.

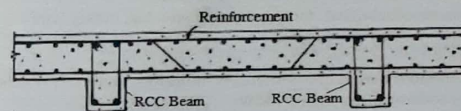

fig. 5.46 Reinforced cement concrete floor (RCC floor)

R.C.C floor: Reinforced cement concrete slab is being more commonly used in the construction of modern buildings. For small spans and comparatively lighter loads, a simple

reinforced cement concrete slab is suitable. If the ratio of the length and width of room is more than 2.0 the slab is known as one way slab and it is designed to span along the shorter direction. In this case the main reinforcement is provided along the shorter dimension of the room. The thickness of the slab depends upon the super imposed loads, span and type of concrete used. The end of these slab rests on the wall, and if the building is constructed in reinforced concrete frames that is in beams and columns, it is essential to construct the slab monolithic with the supporting beams. For larger spans (greater than 4m) and for greater loads, R.C.C beams and slab construction is adopted in the construction of buildings. In such cases the slab act as the flange of the beam and it is cast monolithic with the beams. In this construction size of beam is greatly reduced. Suitable floor covering is laid over the slab to get the desired finish.

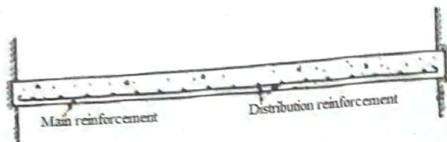

fig. 5.47 Flat slab floor

Flat slab floor: In a flat slab floor, the load on reinforced concrete slab is conveyed directly to the supporting column without beam. This type of construction is adopted when the use of beam is forbidden. The following advantages are claimed by such type of construction.

1. The flat ceiling give better lighting facilities.
2. For the same clear head room, there is a considerable saving in the story height.
3. Even for quite heavy loads thinner sections are enough.
4. Form-work is very simple.
5. Construction of flat slab is simple and easy.
6. It is more economical for live loads grater than 500kg/cm² and spans 4.5 to 9m

Flat slabs are commonly used in commercial buildings, factories, Warehouse, Hospitals etc. But it is not economical for lighter loads.

5.7. FLOOR FINISHING MATERIALS:

Floor coverings are provided to improve the appearance of the floors. It also impart a clean, noise less, and damp-proof surface to the subfloor. The following floor coverings are commonly used.

- | | |
|------------------------------|------------------------------|
| 1. Brick floor covering | 10. Linoleum floor covering |
| 2. Granite floor covering | 11. Glass floor covering |
| 3. Concrete floor covering | 12. Cork floor covering |
| 4. Tiled floor covering | 13. Magnesite floor covering |
| 5. Wood-block floor covering | 14. Plastic floor covering |
| 6. Terrazzo floor covering | 15. Marble floor covering |
| 7. Mosaic floor covering | 16. Synthetic floor covering |
| 8. Asphalt floor covering | 17. Ceramic Flooring |
| 9. Rubber floor covering | |

But now a days we mainly use tiled flooring, mosaic flooring, marble flooring and synthetic flooring.

1 Mosaic floor covering : Mosaic flooring consists of a base concrete and mosaic topping. This type of floor is widely used in theaters, temples and superior type of buildings.

Preparation: A 15cm sand cushion is provided over rammed and watered earthen surface. Over the sand cushion a base course of 10cm thick cement concrete using 1:5:10 mix is placed. The top surface of the concrete is roughly finished to develop good bond between the base and topping. Cure this concrete for 3 days, thus the base floor is ready to apply floor covering(flooring)

Wet the surface of base concrete and apply a 20cm thick cement mortar of proportion 1:2. Glass pieces or marble pieces hammered in to this mortar to get the desired pattern. The inner area is filled with coloured pieces of mosaic chips. After this ordinary cement or colored cement is sprinkled at the top and the surface is rolled using a stone roller till the surface is level. After 24 hours the surface is rubbed with pumic stone to get a smooth, level and polished surface. This polished surface is finally allowed to dry for some week before use.

2. Mosaic Tile flooring : Mosaic Tiles of different size and colour combinations are now available in market. This type of flooring is widely used in residential buiding, shop, theaters, temples and superior type of buildings.

Preparation: A 15cm sand cushion is provided over rammed and watered earthen surface. Over the sand cushion a base course of 10cm thick cement concrete using 1:5:10 mix is placed. The top surface of the concrete is roughly finished to develop good bond between the base and topping. Cure this concrete for 3 days, thus the base floor is ready to apply floor covering(flooring)

In case of old concrete base, thoroughly clean the concrete to remove dust and dirt. Use only water to mop the floor, and allow it to dry completely. Fill any dips or waves with a Portland cement-based floor leveler. Over the concrete bedding, after a period of 2 to 3

days, a cement mortar layer of 1:1 mix is spread, and over that tiles are arranged. A thin paste of cement is applied to their sides. Tiles are then slightly tapped till cement oozes out through the joints to the surface. This oozed out cement is immediately cleaned with sawdust. After 3 days these joints are rubbed with carborundum stone and then by pumic stone. Finally the surface is washed with a weak solution of soft soap in warm water.

3. Ceramic Tile flooring: Ceramic tiles of different colour, size and quality are available in market.

Preparation: A 15cm sand cushion is provided over rammed and watered earthen surface. Over the sand cushion a base course of 10cm thick cement concrete using 1:5:10 mix is placed. The top surface of the concrete is roughly finished to develop good bond between the base and topping. Cure this concrete for 3 days, thus the base floor is ready to apply floor covering (flooring).

Material commonly used for setting and grouting the tile are portland-cement mortar, dry-set or latex portland-cement mortar, organic adhesive. The grouts selected should be chemical-resistant, water-cleanable and have good adhering property. Apply a thin set mortar on the concrete base with the flat side of the trowel, to "key in" the mortar into the concrete within the lines. The trowel is held 45° to the concrete and that angle is held uniformly throughout the installation. The tile placed and lightly beaten in with a mallet. This is to ensure that the tile is seated into the mortar bed.

After beating, the tiles are aligned with the layout lines. Mix the grout according to the Manufacturers instructions. If possible grout small areas at a time. The grout is forced into the joint with the grout float held at approximately 45° diagonally across the face of the tile. The sponge is used to "tool" the joints to a smooth uniform depth. The sponge should be drawn across the tile face diagonally to the joints. Do not overwork the joints and fill any pinholes or voids. This can be accomplished by thoroughly wringing out the sponge and by not applying excess pressure to the sponge. The sponge should be drawn across the tile face diagonally to the joints. Allow the mortar to set for 24 hours before walking over.

4. Tiled floor covering : Clay tiles of different sizes, shapes, thickness and colour are now available in market and are used as surface covering for floor.

Preparation: Over the concrete bedding, after a period of 2 to 3 days, a cement mortar layer of 1:1 mix is spread, and over that tiles are arranged. A thin paste of cement is applied to their sides. Tiles are then slightly tapped till cement oozes out through the joints to the surface. This oozed out cement grout is immediately cleaned with sponge as shown in fig. After 2 or 3 days the surface is washed with a weak solution of soft soap in warm water.

White glazed tiles used for the flooring of water closets, bathrooms, swimming pools etc. These tiles do not require polishing and keep excellent sanitary conditions. They are used for dadoing walls.

Vitrified tiles are very commonly used for the flooring of A-class building. they have zero water absorption property, available in beautiful colour and design. polished vitrified tiles like mirror stone, granamite and marogranite are cheaper than marble and granite.

5. Marble floor covering: Marble flooring is commonly used for superior type of floor construction. Marble slabs may be laid in different size, usually rectangular or square shapes. The base concrete is prepared as for tiled flooring. Over the base concrete 20mm thick bedding mortar of 1:2 mix is spread under each individual slabs. The marble slabs is then laid over this mortar. Gently pressed with wooden mallet and leveled. The marble is then again lifted up, and fresh mortar is added to the hollows of the bedding mortar. The mortar is allowed to harden slightly, cement mortar is spread over it. The edges of already laid slabs are smeared with cement slurry paste, and then the marble slab is placed in position. It is gently pushed with wooden mallet so that cement paste oozes out from the joints, which should be as thin as possible. The oozed out cement is cleaned with sponge. The paved area is cured for a period of seven days.

6. Synthetic flooring: Synthetic materials like *epoxies* and *polyesters* are used in terrazzo floor in thinner layer (less than 1.56mm), than in standard terrazzo floor. The synthetic material replaces cement of the standard terrazzo and they reduce the self weight of flooring. For the preparation of this floor, synthetic material and marble chips mixed with water to get a plastic paste. This mixture laid on the rough base already prepared. Grinding and polishing are performed after 16 to 48 hours.

Agglomerated marble is another material used for flooring and it is prepared by bonding *granules of marble dust* with *Synthetic resins* under high pressure into slabs of different thickness colour and length. They produce a superior floor with the properties of abrasion resistance, resistance to impact, flexibility, resistance to chemical attack, and they are very attractive. They can be installed over existing floors even if the floors are deteriorated. These floors have a nonskid surface and require no waxing. They are weather resistant thus suited for exterior and interior applications.

Vinyl Tiles and *Vinyl asbestose tiles* (PVC or PVA tiles or sheets) of different colours, size and design are now available in market. Since vinyl resins are tough synthetic polymers, vinyl flooring can with stand heavy loads without indentation, and is resilient and comfortable under foot. It is practically unaffected by grease, fat, oils, household cleaners, or solvents. These tiles can be fixed on the floor by spreading hot bitumen adhesive on the subbase and the surface is rolled with light roller.

5.8. HVAC SYSTEM

Heating, ventilation, and air conditioning (HVAC) system is designed to achieve the environmental requirements of the comfort of occupants. HVAC systems are more used in different types of buildings such as industrial, commercial, residential and institutional buildings. The main mission

of HVAC system is to satisfy the thermal comfort of occupants by adjusting and changing the outdoor air conditions to the desired conditions of occupied buildings. Depending on outdoor conditions, the outdoor air is drawn into the buildings and heated or cooled before it is distributed into the occupied spaces; then it is exhausted to the ambient air or reused in the system. The selection of HVAC. The heating, Ventilation and Air conditioning (HVAC) system is to provide healthy and comfortable interior conditions for occupants. Well designed and efficient systems do this with minimal non-renewable energy and air and water pollutant emissions. HVAC systems in a given building will depend on the climate, the age of the building, the individual preferences of the owner of the building and a designer of a project, the project budget, the architectural design of the building.

HVAC systems can be classified according to necessary process. The required processes include the heating process, the cooling process, and ventilation process. Other processes can be added such as humidification and dehumidification process. These process can be achieved by using suitable HVAC equipment such as heating systems, air-conditioning systems, ventilating fans, and dehumidifiers. The HVAC systems need the distribution system to deliver the required amount of air with the desired environmental condition. The distribution system mainly varies according to the refrigerant type and the delivering method such as air handling equipment, fan coils, air chutes, and water pipes.

3.8.1. Selection of HVAC system

System selection depends on three main factors including the building configuration, the climate conditions, and the owner desire. The design engineer is responsible for considering various systems and recommending more than one system to meet the goal and satisfy the owner of a building. Some criteria can be considered such as climate change (e.g., temperature, humidity, and space pressure), building capacity, spatial requirements, cost such as capital cost, operating cost, and maintenance cost, life cycle analysis, and reliability and flexibility. However, the selection of a system has some constraints that must be determined. These constraints include the available capacity according to standards, building configuration, available space, construction budget, the available utility source, heating and cooling building loads.

3. Basic components of an HVAC system

The basic components or equipment of an HVAC system that delivers conditioned air to satisfy thermal comfort of space and occupants and the achieve the indoor air quality are listed below:

- a. Mixed-air plenum and outdoor air control
- b. Air filter
- c. Supply fan
- d. Exhaust or relief fans and an air outlet
- e. Outdoor air intake
- f. Ducts
- g. Terminal devices
- h. Return air system

- i. Heating and cooling coils
- j. Self-contained heating or cooling unit
- k. Cooling tower
- l. Boiler
- m. Control
- n. Water chiller
- o. Humidification and dehumidification equipment

The major classification of HVAC systems is central system and decentralized or local system. Types of a system depend on addressing the primary equipment location to be centralized as conditioning entire building as a whole unit or decentralized as separately conditioning a specific zone as part of a building.

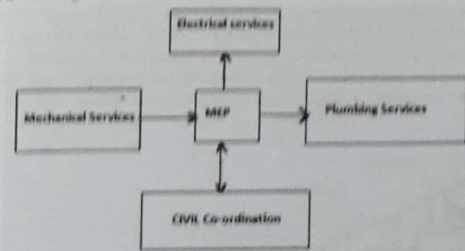

Fig 5.4B

5.9. MEP

MEP Engineering is the services and art of planning, designing and managing the MEP system of a building. An MEP design systems are the central nervous system of a building and are responsible for the "creature comfort" features of a structure. they make a building livable and pleasant.

The mechanical design elements of a building, the heating and cooling systems, which help to make life inside more comfortable. These systems allow us to occupy building in hot and cold, under all weather conditions. The electrical system in a building keeps the lights on keeps our devices powered, and keeps the other systems running. Architectural lighting design and plans are a crucial component of electrical engineering process.

We cannot imagine a building with out plumbing facility. Plumbing system provide fresh water for drinking, cleansing and more. And they take the storm and sanitary wash water away, safely.

Plumbing services

1. Domestic Water system

2. Flushing Water system
3. Rain Water System
4. Sewage Water System
5. Water Treatment Plant
6. All piping & Sanitary Fixtures that provide water for any use

5.10 STAIRS

Stairs are series of steps properly arranged to connect different floors of a building. The room of a building in which steps arranged in series, so as to provide comfort and safety to the persons using them in addition to easy and quick access to various floors, is called staircase.

The stairs should be located such that they serve the purpose for which they are provided. It needs careful planning and consideration of all probable factors. In case of fire or any other emergency situations the stairs are only means of communication.

Generally, stairs are placed near the main entrance in public buildings. In residential building stairs are provided in the centre for easy access to all the dwellers and also for privacy.

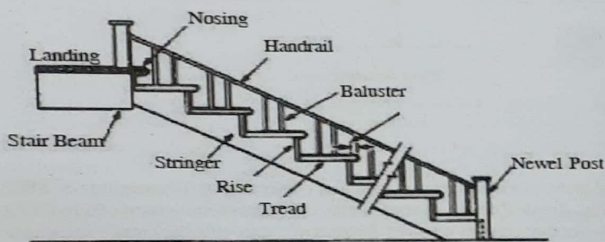

Fig 5.49 Building services

Reinforced cement concrete Stairs and Metal stairs are commonly used now a days.

1. **Tread** : Flat or horizontal upper portion of a step on which the foot is placed for ascending or descending.
2. **Riser** : Vertical member between two treads is known as riser.
3. **Rise** : It is the vertical distance between surface of two consecutive steps.
4. **Going** : It is the horizontal distance between the faces of two consecutive risers.
5. **Flight** : A series of steps with out any intermediate platform.
6. **Landing** : Flat platform at the head of a series of steps.
7. **Nosing** : The outer projection of a tread is known as nosing.

8. **Line of Nosing** : A imaginary line connecting the nosing points parallel to the slope of the stair.

9. **Handrail** : wooden or metallic rail is generally provided on the side of stairs at about waist height at an inclination or at level on a landing.

10. **Newels** : Posts set at the top and bottom of a stair supporting the handrail.

11. **Strings** : Sloping members which support the steps in a stair.

12. **Baluster** : It is the vertical member placed between string and handrail to provide support to the handrail.

13. **Balustrade** : The combined framework of handrail and balusters is called as balustrade.

14. **Flier** : It is a straight step having a parallel width of tread.

15. **Soffit** : It is the under surface of a stair.

5.19.1. Types of stairs

Depending up on the shape of construction of stairs, they are classified as:

- a. **Straight flight stair** : The stairs continue throughout their entire length in one direction only. This may consist of a single flight with one or two landing in between.
- b. **Quarter turn stairs** : When the direction of flight is changed at right angles either to the left or to the right, quarter turn stairs are used. These are of two types. In the first type the change in direction is effected by introducing a quarter space landing.
- c. **Half turn stairs** : In this type of stairs the direction of flight is reversed that is turned by 180° by the introduction of landings. The landing is described as a half space or half turn landing. A half turn stair is often described as a 'dog leg' stair because it looks somewhat like the hind leg of a dog in section. In this type there is no gap between the flights. This type of stair used when space is restricted. (see figure)

In case of open well stairs an opening or well is present in between the stringers. This gives better appearance but require more width.

- d. **Three quarter turn stairs** : In this type of stair the direction changed three times with its upper flat crossing the bottom one.

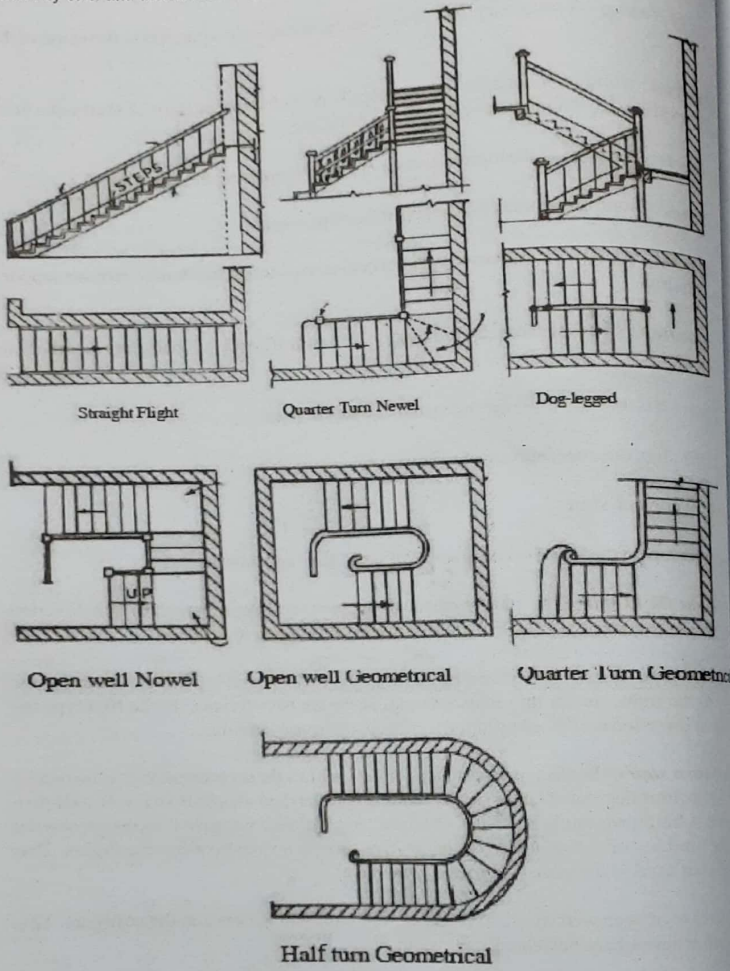

Fig 5.50

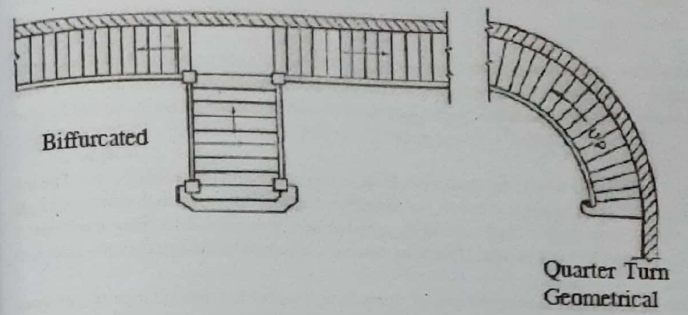

fig 5.51

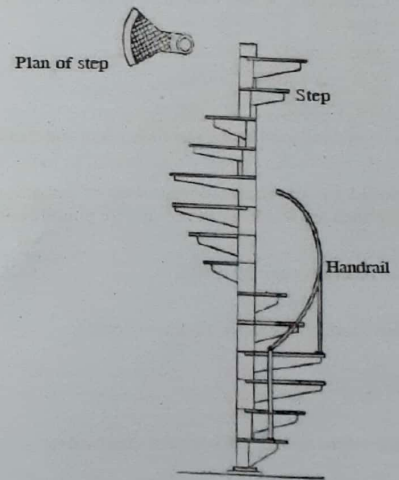

Fig 5.52

e. **Bifurcating stair** : In this type of stair, the wide bottom flight is divided into two narrow flights at landing as in fig.

f. **Geometrical or continuous stairs** : The strings and handrails are continuous and are set out in accordance with geometrical principles. Different models are shown in fig.13.3

g. **Spiral Stairs** : In this type the steps project from a central post or pillar in a spiral form as in fig.

This type of stairs used where the space available is too small and the traffic is less. The use of spiral staircase shall be limited to low occupant load and buildings upto 9 metres in height unless they are connected to platforms such as balconies and terraces to allow easy exit. A spiral staircase shall be not less than 150 cm in diameter and shall be designed to give adequate head room.

h. **Circular or elliptical stairs**: Elliptical stairs are constructed around a generous open well with the treads having a shallow taper towards the well. These stairs, which are used in excessive space, are used as a feature for grand means of access in large buildings.

5.10.2. Essential Requirements of a good staircase

a. Step proportions- it should not be too wide or too short. Proportion of tread and rise should be in such a way that

$$40\text{cm} < (\text{rise} + \text{tread}) > 45\text{cm}$$

$$58\text{cm} < (2 \times \text{rise} + \text{tread}) > 63\text{cm}$$

$$400\text{cm} < (\text{rise} \times \text{tread}) > 500\text{cm}$$

For important buildings rise should not be greater than 18cm and tread not less than 27cm.

b. Width of stair should be adequate for number of people expected to use. For residential building recommended width one metre and for public building 1.5metres.

c. Slope of stairs should be in between 20 to 40°.

d. All the treads and rises should be of uniform dimensions.

e. Staircase should be well lighted.

f. For a single flight number steps should not be greater than twelve.

g. Sufficient Head room (vertical distance between the tread of a step and the bottom of flight or landing immediately above it) should be provided ie. 2.1m.

5.11. Ramps

Ramp is an inclined plane joining two floors and is mainly used for carrying machinery, equipments, trolleys, cars etc. to upper floors in multistoried building and public buildings. Ramps are either located externally i.e. extending from the general building line or inside the building. In case of movement of heavy loads it is preferable to provide the ramp externally, whereas for pedestrians, it is preferable to provide inside the building.

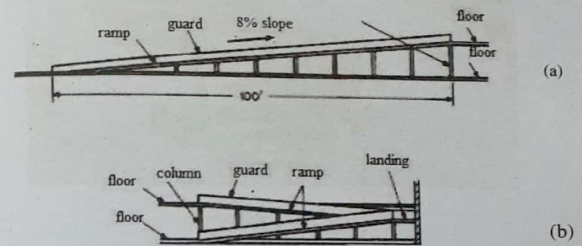

fig 5.53. (a) straight ramp and (b) Zig-zag ramp

The dimensions of the ramp also depends upon its use. For pedestrian traffic, a minimum slope of 1 in 10 and a maximum of 1 in 8 can be adopted. Its width is limited to about 2m and can be of dog legged type in plan. Landing at every change in direction are provided with width equals to that of the ramp. Hand rails to be provided on both the sides of ramp. The ramp need not be straight for the whole distance, however. It can be zigzagged as in figure 13.2

For carrying cars and other machinery, much greater dimensions are required. Normally ramps are designed as inclined R.C.C. slabs supported on columns. Floors are surfaced with non slipping materials or transverse grooves to be provided on surface for providing sufficient friction..

5.12. Escalators:

Escalators, or powered stairs, are used when it is necessary to move large numbers of people from floor to floor. They provide continuous movement of persons and can thus remedy traffic conditions that are not readily addressed by elevators. Escalators are preferred transportation systems whenever heavy traffic volumes are expected between relatively few floors.

Escalators are used to connect airport terminals, parking garages, sports facilities, shopping malls, convention centers, hotels, public buildings and numerous mixed-use facilities. Although escalators generally are used in straight sections, spiral escalators also are available.



fig 5 .54 Escalator

General specification:

- Speed: - 0.46 to 0.50m/sec
- Angle of inclination - 30° to 35°
- Width - Normally width are 61cm, 91.4cm and 1.22m.

Design of escalator is carried out with a handling capacity for 3200 to 6400 persons/hour. building design must be for minimising the usage of municipal water supplies, and will aim to use water at the site. This may be accomplished by using a dual water system, using non-potable water for the landscape, maintenance and toilets.

It is found that the building industry will consume 40% of total global energy / source and release about 3800mega tons of CO₂ into atmosphere. They have harmful impact on the nature.

- (i) Consumption of 40% of world's total energy.
- (ii) Consumption of 30% of raw materials.
- (iii) About 25% of timber harvest is going down.
- (iv) 35% of CO₂ emission.
- (v) 16% of fresh water is being depleted.
- (vi) 40% of municipal solid waste is being generated.
- (vi) 50% of ozone depleting CFC's are still in use

he benefits of escalators are: they have the capacity to move large numbers of people, and they can be placed in the same physical space as one might install a staircase. They have no waiting interval, they can be used to guide people toward main exits or special exhibits.

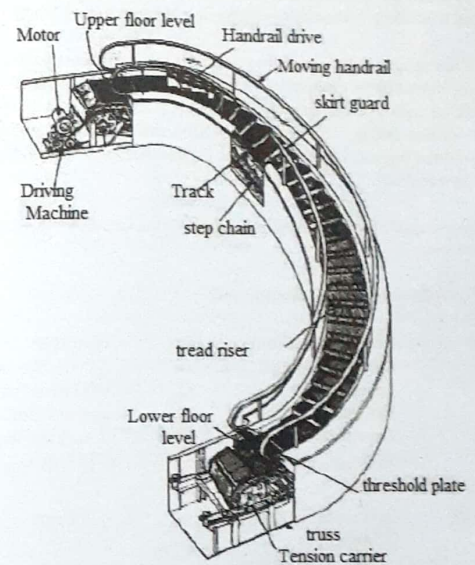

Fig. 5.55 Sprral escalator

5.13. LIFT OR ELEVATOR

Lift is an appliance designed to transport persons or materials between two or more levels in a vertical or substantially vertical direction by means of guided car or platform. For multi-storied buildings, the installation of lift is essential to avoid fatigue in climbing up the stairs and for quick vertical movement between floors.

Primitive lifts were in use as early as the 3rd century BC, operated by human, animal or water wheel power. From about the middle of the 19th century, power lifts, often steam operated, were used for conveying materials in factories, mines, and warehouses. In 1852, American inventor Elisha Otis demonstrated a freight elevator equipped with a safety device to prevent falling in case the supporting cable break. This increased public confidence in using lift like devices. Electric elevators came into use towards the end of the 19th century and the first one was built by the German inventor Werner von Siemens in 1880.

Types of lift selected for a building depends on the quantity of services required, the quality of service desired. Quantity of service gives the passenger handling capacity during the peak periods and the quality of service is measured in terms of waiting time of passengers at various floors. The number of lifts, their capacity and speed required for a building is governed by such considerations as number of floors to be served, number of passengers to be handled.

Quality of services: quality of services is generally measured by the *passenger waiting time* at the various floors.

5.13.2. Speed of lifts in different occupancies:

- Passenger lift**
 - Low and medium class flats - 0.5m/sec
 - Office buildings, hotels - 0.5 to 0.75m/sec
 - Large flats - 0.75 to 1.5m/sec
 - Hospitals - above 1.5m/sec
 - Departmental stores - 2 to 2.5m/sec
- Goods lifts**
 - Normal case - 0.25 to 0.5 m/sec
 - Serving main floors - 1m/sec
- Hospital bed lift**
 - Short travel in small hospital - 0.25m/sec
 - Normal - 0.5m/sec
 - Long travel lift in large hospital - 1.0m/sec

Acceptable interval	Class
20 – 25 sec	Excellent
30 – 35 sec	Good.
35 – 40 sec	Fair
40 – 45 sec	Poor
Over 45sec	Unsatisfactory

How Lifts Work : In a typical elevator, the car is raised and lowered by six to eight driven wire ropes that are attached to the top of the car at one end. These wires, travel

a pair of sheaves, and then attached to a counterweight at the other end. The counterweight adds accelerating force when the elevator car is ascending and provides a retarding effort when the car is descending. The counter weight is a collection of metal weights that is equal to the weight of the car plus about 45% of its rated load. A set of chains are looped from the bottom of the counterweight to the underside of the car to maintain balance by offsetting the weight of the suspension ropes. Guide rails, keep the car and the counterweight from swaying or twisting during their travel. Rollers are attached to the car and the counterweight to provide smooth travel along the guide rails.

5.14 FIRE SAFTY FOR BUILDINGS

Even in well designed buildings fire may occur in due to various unexpected reasons. To protect the life and valuable appliances, sufficient fire fighting arrangements should be provided in the building. Fire fighting system consists of (i) early warning system on out break of fire and (ii) the fire extinguishing arrangements.

5.14.1 Fire Detection and warning system

Fire detection and warning system is for facilitating adequate warning to the inmates. Automatic Fire detection and Alarm system to be provided in building to warn the people and give them enough time to escape from the building. As per National Building code, all buildings having height more than 15m should be equipped with manually operated electrical fire alarm system (MOEFA) and automatic fire alarm system.

Fire fighting System

Water, carbon dioxide and foam are used as fire fighters. The firefighting arrangements consists of :

fire extinguishers/ Fixed firefighting installations: Depending upon the height of buildings and occupants fire –protection arrangements should be provided with installation of fire extinguishers, wet risers,downcomers, automatic sprinklers, foam, gaseous or dry powder system as mentioned in NBC.

Water Tanks: As an alternate source of water supply for firefighting an additional water tank to be provided on the roof top or below the ground level. And arrangements should be provided to supply 1000lit/ minute. This tanks should be easily assessable to the firefighting arrangements.

Automatic sprinklers: Automatic sprinkler arrangements should be provided in all high altitude buildings.

Automatic high velocity water sprayers or emulsifying system: Automatic high velocity water sprayers or emulsifying system are used for providing protection for oil cooled transformers.

Fixed foam installation: Fixed foam firefighting provided for the protection oil storage area and where there is high chances of explosion.

Carbon dioxide fire extinguisher system: Carbon dioxide fire extinguishers are fixed in building where there is difficulty in fixing water or foam extinguisher. In cases of building which are not able to use carbon dioxide, water, foam extinguisher, we can use Bromo chlorodifluoro methane (BCF) or Bromo chloro trifluoromethane (BTF) as fire extinguisher.

Potable fire extinguisher: Standard potable fire extinguishers are

- (i) Water CO₂ of capacity in litres.
- (ii) CO₂ fire extinguisher of capacity 4.5kg.

Number of fire extinguisher for a building and its location clearly mentioned in National Building Code Part IV.

Exercise

1. What are the constituents of good brick earth?
2. Enumerate the qualities of good bricks?
3. How the classification of brick is made?
4. What is the difference between Hollow bricks and Perforated bricks?
5. Explain how the following tests for bricks are carried out
i. Absorption test ii. Hardness test iii. Crushing Strength test
6. Define the following: i. Frogs ii. Bat iii. Closer iv. Bullnose
7. Differentiate between King closer and Queen closer
8. What are the different types of brick masonry?
9. Explain with neat sketch the difference between English bond and Flemish bond?
10. Explain briefly about brick bond. Sketch one brick English bond.
11. Explain factors affecting strength of brick masonry.
12. What are the different tests used for checking the quality of brick?
13. What are the requirements of a well planned roof?
14. Give neat sketch of a lean to roof and name the various parts.
15. Define a pitched roof. Describe the various types of pitched roofs used for residential buildings with sketches.
16. Explain with figures the different types of trussed roof.
17. Explain MVAC and MEP
18. Essential requirement of good stair.
19. Write short note on lift, ramp and escalator, fire safety measures of building.

GREEN BUILDING

6.1. INTRODUCTION

Green building is a loosely defined collection of land-use, building design, and construction strategies that reduce the environmental impacts that buildings have on their surroundings. Traditional building practices often overlook the interrelationships among a building, its components, its surroundings, and its occupants. "Typical" buildings consume more of our resources than necessary and generate large amounts of waste. A green building can be considered identical to a tree that would purify air, accrue solar income, produce more energy than it consumes, create shade & shelter, enrich soil & change with seasons.

There is a need to use our energy resources very efficiently by using sustainable buildings. Within 10 years when compared to conventional buildings we can reduce the electricity consumption by 85% & gas consumption by 93%. So these buildings are eco-friendly, we need to create awareness about the construction of Green Building for minimizes on-site grading, saves natural resources by using alternative building material and recycles construction waste rather than dumping in landfill. Green Building's interior spaces have natural lighting, outdoor views while highly efficient heating, ventilating and air conditioning (HVAC) systems and low volatile organic compounds like paints, flooring and furniture create a superior indoor air quality.

6.1.1. Benefits of green building

Green building offers a host of environmental, economic, and health and community benefits. USGBC notes the following benefits:

i. Environmental Benefits:

- (i) Enhancement and protection of ecosystems and biodiversity
- (ii) Improvement of air and water quality
- (iii) Reduction of solid waste by using recycled building materials
- (iv) Conservation of natural resources

ii. Economic benefit:

- (i) Reduction of operating and energy costs
- (ii) Enhancement of asset value and profits
- (iii) Improvement of employee productivity and satisfaction by reducing indoor building environmental characteristics that may lead to Sick Building Syndrome
- (iv) Optimization of life-cycle economic performance

- (ii) Improvement of air and water quality
- (iii) Reduction of solid waste by using recycled building materials
- (iv) Conservation of natural resources

ii. Economic benefit:

- (i) Reduction of operating and energy costs
- (ii) Enhancement of asset value and profits
- (iii) Improvement of employee productivity and satisfaction by reducing indoor building environmental characteristics that may lead to Sick Building Syndrome
- (iv) Optimization of life-cycle economic performance

iii. Health and community benefit

- (i) Improvement of indoor air, thermal, and acoustic environments.
- (ii) Enhancement of comfort and health for employees, tenants, students, and customers.
- (iii) Minimization strain on local infrastructure by using less energy, water, and reducing solid waste
- (iv) Improvement of overall quality of life for employees, tenants, students, and customers.
- (v) 30% to 40% reduction in operating cost.
- (vi) Health and safety of building occupants.
- (vii) Incorporate latest techniques and technologies.
- (viii) The most tangible benefit is in reduction of operating energy and water costs right from first day to the entire life cycle of the building.

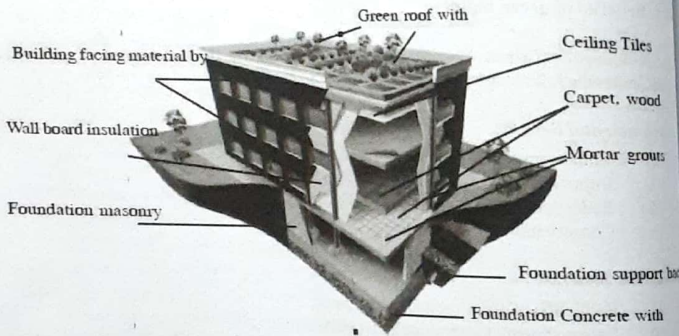

Fig 6.1 Green Building

6.2. GREEN BUILDING MATERIAL

Green building is about making the best use of resources during all stages of construction. By combining a system of components and materials that work in harmony with one another, the goal is to create an energy-efficient, water-saving structure with a low carbon footprint. While selecting the right materials is a large part of green building, choosing the best materials may not be obvious and will depend on the needs of the building owner.

Green building materials offer specific benefits to the building owner and building occupants:

- (i) Reduced maintenance/replacement costs over the life of the building.
- (ii) Energy conservation.
- (iii) Improved occupant health and productivity.
- (iv) Lower costs associated with changing space configurations.
- (v) Greater design flexibility.
- (vi) Providing an environment friendly building

6.1. Green Building materials for different parts of building

a. Green Roofs & Landscaping

Green roofs are roofs covered with plants; they reduce storm runoff and provide insulation. Scrap tires can be used to make rubber tile for walkways. Bottom ash can be used as bedding material. Clean wood, recycled gypsum wallboard, and cardboard can be ground and used as soil amendments in both green roofs and landscaping applications.

b. Landscape Furniture

Benches can be made with plastic lumber containing fly ash or with recycled C&D wood.

c. Building Facing Material

Manufactured stone, which is concrete mixed with aggregates, is commonly used as building facing material. Fly ash can be used in the production of manufactured stone.

d. Sidewalks

Industrial materials can be used to make concrete sidewalks, and used tires can be recycled to create rubberized sidewalks. Asphalt concrete sidewalks can be made with recycled asphalt pavement and recycled asphalt shingles.

e. Ceiling Tile

Ceiling tile can contain flue gas desulfurization (FGD) gypsum (a material resulting from burning coal to produce electricity), fly ash, recycled gypsum wallboard, or air-cooled blast furnace slag.

f. Flooring

Industrial materials can be used in various flooring applications.

- (i) Carpet backing: Used tires, fly ash, or recycled carpet.
- (ii) Wood flooring: Salvaged lumber or recycled wood.
- (iii) Flooring tile: Fly ash, blast furnace slag.
- (iv) Tile underlayment: Fly ash.

g. Backfill (Foundation Support)

Backfill surrounds the building foundation, supporting it and providing drainage. Scrap tires provide superior drainage, insulation, and wall pressure relief. Blast furnace slag and recycled concrete also can be used for drainage.

h. Foundation Structural Fill

Structural fill is an engineered fill that is constructed in layers and compacted to a desired density. Coal fly ash, bottom ash, slag, and spent foundry sand can all be used as structural fill. Concrete can be crushed and used onsite as structural fill.

i. Poured Concrete Foundation

Concrete, which is composed of cement, aggregate, and water, is used in a wide array of building applications. Industrial materials can be recycled in cement and concrete in many ways. Portland cement itself can be made with fly ash, FGD gypsum, foundry sand, recycled concrete aggregates can include bottom ash, foundry sand, crushed concrete, and blast furnace slag.

j. Insulation

Air-cooled blast furnace slag can be used to produce mineral or rock wool insulation (also known as slag wool insulation).

k. Drywall/Wallboard

FGD gypsum and recycled gypsum wall board can be used to manufacture drywall.

l. Mortars, Grouts, Stucco

Mortars, grouts, and stucco contain aggregate (sand), binder, and water. Fly ash, foundry sand, silica fume, and slag cement can all be used as partial cement replacements.

m. Masonry Blocks

Masonry blocks are made from cement and aggregate. Slag cement, fly ash, or silica fume can substitute partially for cement. Bottom ash, blast furnace slag, and recycled concrete aggregate can substitute for newly mined materials.

n. Base Material

Spent foundry sand can be used in place of natural soil as base material for the building site. In cold weather climates, this strategy can extend the construction season because foundry sands do not freeze as readily as most soils. Recycled concrete is also commonly used as base material for reducing cost of construction.

6.3. RECYCLED BUILDING MATERIAL

Another sustainable construction practice is to use of the recycled materials in building construction viz, demolished building waste, industrial waste and construction site waste materials as an alternative to virgin construction materials. The major advantages of using recycled materials in construction are

- a) It reduces the demand up on new resources.
- b) Cuts down the cost and effort of transport and production.
- c) Use waste which would otherwise be lost to landfill sites.
- d) Pollution of land and water sources and can be reduced.

The materials from demolished buildings and construction site wastes are often disposed of as waste and used for land filling purposes. But with proper engineering approach most materials can be recycled.

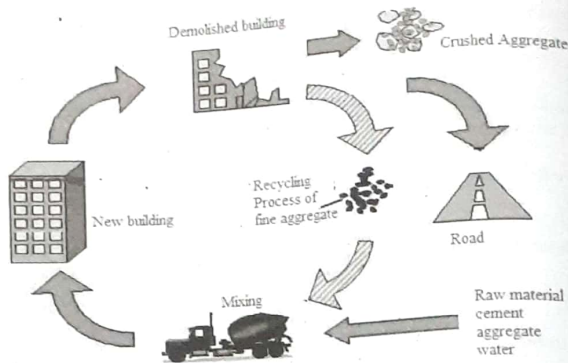

Fig 6.2. Recycling of building material

6.4 Reuse options in building construction.

Concrete - Unset concrete can be 'washed' out at the plant to remove cement. Sand and stone can be reused. Set concrete can be crushed and recycled as aggregate for new concrete or road base and for land filling.

Steel: Electric arc furnaces produce reinforcing bar, mesh and sections from 100% steel scrap.

Aluminum : Aluminium collected from demolished building is 100% recyclable.

Gypsum plastered wall: CSR recycles plasterboard. If disposed to landfill, it produces poisonous hydrogen sulphide and has a foul odour.

Timber: timber can be reprocessed into horticultural mulch.

Brick Tiles: Brick tiles can be reused where appropriate or crushed onsite for backfill, aggregate and gravel with portable crushing plants.

Plastics: Many plastics can be granulated and reused to make new plastic products for use within the building industry.

Most Glass: Most glass can be recycled. Construction glass must be separated from other glass such as drink bottles. Glass may be cut and reused or recycled as aggregate for concrete.

Carpet: Carpet in good condition can be sold and reused. It can also be recycled into secondary carpets. Some carpet can be recycled as weed barriers or a covering and food for worm farms. Examples of industrial waste materials that can be recycled include fly ash, spent foundry sand, used tires, and slag. Fly ash and slag can be used for manufacture of fly ash cement.

The practice of recycling of construction materials and usage of suitable substitute for aggregate should be considered only after proper certification from an engineer after re-evaluating technical specification for materials. It is desirable to reduce the construction waste by arranging only the correct amount of raw materials during construction phase. Also when a structure is being demolished, salvage as much of the more valuable fittings and materials as possible.

Exercise

1. What is meant by sustainable building?
2. What is meant by Green building?
3. What are the advantages of green building?
4. Write note on green building materials.
5. What are the advantages of recycled material?
6. Draw a neat sketch of King-post truss and explain different components.
7. Draw the sketch of Queen-post truss and indicate its components. Describe the functions of each of them.
8. What are the advantages of steel truss ?
9. Describe with neat sketch the various types of flat floors.
10. Compare the merits of A.C. sheet, G.I.sheets and PVC roofs.